



**PUNJAB STATE TRANSMISSION CORPORATION LIMITED,**  
**Regd. Office: PSEB Head Office, The Mall, Patiala-147001**  
**Corporate Identity Number : U40109PB2010SGC033814**  
**Office of Chief Engineer /Transmission System,**  
**3<sup>rd</sup> Floor, Shakti Sadan, Patiala-147001**

Telephone: 0175-2303676 e.mail [ce-tl@pstcl.org](mailto:ce-tl@pstcl.org) FAX 0175-2301536, 2207774

**TENDER ENQUIRY NO. STQ- 4005 / 2014-15**

**SPECIFICATION AND GENERAL INSTRUCTIONS FOR DESIGN, MANUFACTURE, TESTING, SUPPLY & DELIVERY OF HARDWARE FITTINGS AND ACCESSORIES SUITABLE FOR EARTHWIRE OF SIZE 7/3.15 MM.**

**DUE DATES AND TIME FOR:**

- |  |   |                                 |
|--|---|---------------------------------|
| i) Downloading of Tender Specification | : | 02.02.2015 up to 11.00 Hrs.     |
| ii) Receipt of tenders                 | : | 05.02.2015 up to 11.00 Hrs.     |
| iii) Opening of tenders                | : | 05.02.2015 at 11.30 Hrs.        |
| iv) Cost of tender documents           | : | Rs 500/- (Rs Five hundred only) |

i) Suspension clamp 7/3.15mm	= 2.60 lac
ii) 4 R-Stock bridge Dampers 7/3.15mm	= 3.35 lac
Total = 5.95 lac	

PRICE: RS. 500/- (RUPEES FIVE HUNDRED ONLY)

**INDEX**

S. No.	DESCRIPTION	PAGE NO.
1.	TENDER NOTICE	3-5
2.	IMPORTANT NOTE FOR GUIDANCE OF BIDDERS	6-8
3.	GENERAL INSTRUCTIONS (Part-A)	9-26
4.	TECHNICAL SPECIFICATION (Part-B)	27-38
5.	Annexure-A (PRICE SCHEDULE) COMMERCIAL INFORMATION	39
6.	Annexure-B (SCHEDULE OF REQUIREMENTS AND DELIVERY)	40
7.	Annexure-C (PROFORMA FOR BANK GUARANTEE)	41
8.	Annexure-D (UNDERTAKING FORM) FOR ORDER PREFERENCE	42
9.	Annexure-E (CONTRACT AGREEMENT FORM)	43
10.	Annexure-F (APPRAISAL OF FIRM'S)	44-45
11.	Annexure-G (SCHEDULE OF GENERAL INFORMATION)	46
12.	Annexure-H (SCHEDULE OF DEVIATIONS)	47
13.	Annexure-I (TESTING FACILITIES)	48
14.	Annexure-J (SCHEDULE OF TECHNICAL INFORMATIONS)	49
15.	Annexure- K-1 (GUARANTEED TECHNICAL PARTICULARS FOR SUSPENSION CLAMP HARDWARE FITTINGS E/W 7/3.15MM)	50
16.	Annexure K-2 (GUARANTEED TECHNICAL PARTICULARS 4R Stock Bridge Dampers suitable for E/W 7/3.15MM)	51
17.	Annexure-L (GENERAL COMMERCIAL PARTICULARS)	52
18.	Annexure-M (UNDERTAKING FOR NON PAYMENT OF COMMISSION etc.)	53
19.	DRAWINGS	54 to 55

**PUNJAB STATE TRANSMISSION CORPORATION LTD.**

**TENDER NOTICE**

Department Name	Transmission System, PSTCL, Patiala	
Tender Specification No.	STQ- 4005	
Tender Issuing Authority	Chief Engineer/TS	
Address Detail of Issuing Authority	Chief Engineer/TS, 3 <sup>rd</sup> Floor, Shakti Sadan, PSTCL, Patiala	
Place	Patiala	
Short Description	<p>Manufacture, testing, supply &amp; delivery of Hardware Fittings and accessories suitable for earth wire of size 7/3.15 mm conforming to IS-2486/1971 (Part-1), IS-2121, IS-9708 read with latest amendments, if any and PSTCL's tender specification No. STQ- 4005 for 220 KV Lines</p> <p><b><u>Earthwire of Size 7/3.15mm</u></b></p> <p>(i) Suspension Clamps</p> <p>(ii) 4 R- Stock Bridge Dampers</p>	<p>Qty. (Nos.)</p> <p>800</p> <p>1100</p>
Tender Publication	In leading National Dailies of India in English/ Punjabi	
Eligibility Criteria	The supplier shall have required facility of manufacturing, testing & supply as per tender documents/specification No. STQ- 4005	
Starting/Ending date of down loading from the website <a href="http://www.pstcl.org">www.pstcl.org</a> a) Start Date b) End Date	<p>Date of Publication</p> <p>02.02.2015 up to 11.00 hrs.</p>	
Last date of Bid submission	05.02.2015 up to 11:00 hrs.	
Bid opening date	05.02.2015 at 11:30 hrs.	
Pre-bid meet date	N.A.	
Tender Document Cost	Rs. 500/-	
Payment mode:	Demand Draft	
Payment in favour of	Accounts Officer, CPC, PSTCL, Patiala	
EMD	As per rates prescribed in tender documents	
Mode of payment of EMD	Demand Draft or PEMD with CE/TS, PSTCL, Patiala	
Payment in favour of	Accounts Officer/CPC, PSTCL, Patiala	
Contact Persons name	<p>Chief Engineer /TS, PSTCL, Patiala</p> <p>Dy. CE/ TS (Design), PSTCL, Patiala</p> <p>Addl.SE/T&amp;S-IV, PSTCL, Patiala</p>	
Contact Phone Nos.	<p>0175- 2301536 (CE/TS)</p> <p>0175- 2207774 (Dy. CE/TS (Design))</p>	

	0175-2217703 to 07 Extn. 370 (Addl.SE/T&S-IV)
Contact e-mail I.D	se-trd@pstcl.org
URL for additional Information	<a href="http://www.pstcl.org">www.pstcl.org</a>
Tender Document Attachment	---
Tender Information Detail	<p>1 No hard copy of the specification shall be issued. A set of tender documents containing technical specifications, General instruction and terms &amp; conditions can be downloaded from website <a href="http://www.pstcl.org">www.pstcl.org</a> .The cost of the tender specification shall be submitted by the bidders in form of demand draft in favour of Accounts Officer, CPC, PSTCL, Patiala, , in the office of the Chief Engineer/TS, 3<sup>rd</sup> Floor, Shakti Sadan, PSTCL, Patiala. Bids of the firms which do not submit the demand draft towards cost of specification as mentioned above shall not be considered. The demand draft towards cost of specification shall be submitted in an envelope clearly super –scribed with the words, "<b>cost of specifications against tender enquiry no. STQ-4005</b>". The cost of bidding document is non-refundable.</p> <p>2. All the tenders must be accompanied by Earnest Money at the rates prescribed in tender document except in the case of those tenderers who are specifically exempted there under.</p> <p>3. Telegraphic quotations shall not be accepted.</p> <p>4. Negotiations, if required, shall not be held except with the lowest tenderer.</p> <p>5. PSTCL reserves the right to increase/decrease the NIT quantity or to reject the whole NIT quantity without assigning any reason.</p> <p>6. The offers should be kept valid for at least 120 days from the date of opening of tenders.</p> <p>7. The competent authority may distribute the quantity to be procured on one or more firms.</p> <p>8. The firms indicating NIL or concessional rate of E.D &amp; CST/VAT in their tenders will have to absorb E.D &amp; CST/VAT up to the full rate applicable at the time of tendering.</p> <p>9. Tenders received after the due date &amp; time, even if posted before the due date of opening, shall not be entertained at all.</p>

	<p>10. Conditional tenders will not be accepted.</p> <p>11 The part-III of the tenders i.e. price bids of Blacklisted and debarred firms shall not be opened.</p> <p>12. The prospective bidders are requested to visit the PSTCL website periodically even after down-loading the specification to check for corrigendum issued, if any.</p>
--	---

Dy. CE/TS (Design),  
PSTCL, Patiala

### **IMPORTANT NOTES FOR GUIDANCE OF BIDDERS**

- The detailed breakup of prices as desired in the price schedule (ANNEXURE – A) must invariably be filled in the first instance while submitting the tender. Other information as per Annexure must also be supplied. In the absence of above, the tender is liable to be rejected.
- Quantity mentioned in the NIT could be ordered on more than one supplier.
- The firms indicating NIL or concessional rate of CST/VAT in their tenders will have to absorb the CST/VAT up to full rate applicable at the time of bidding. The firms who do not agree to this stipulation or indicate CST/VAT as extra without indicating the applicable rate shall be loaded with maximum rate of CST/VAT for evaluation purpose.
- The firms indicating NIL or concessional rate of ED in their tenders will have to absorb the ED up to full rate applicable at the time of tendering. The firms who do not agree to this stipulation or indicate ED as extra without indicating the applicable rate shall be loaded with maximum rate of Duty for evaluation purpose.
- The Tender documents submitted should be wholly typed or printed. As a first principle there should be no cutting/over writings or erasion. However, any unavoidable cutting/over writings should be duly signed and authenticated **Tender should be wholly typed or printed.**
- Any deviation in Technical & General conditions must be indicated, otherwise it would be assumed that the material offered is entirely as per enclosed Technical specification & General conditions and acceptable to the Tenderer in to-to.
- The tenderer revising their offer or withdrawing the same within validity period after opening of tender are liable to be rejected / black listed.
- Conditional / Non conforming bid shall not be accepted.
- The tenderers will have to give an undertaking that they will not pay any commission etc or engage any commission agent or liaison agent for dealing with PSTCL in any matter including purchase of specification etc. This undertaking is required to be supplied along with the offer/Tender, failing which their offer/Tender is likely to be ignored.
- Bidders should invariably supply documents for constitution & composition of the firm's as per Clause 28 of Part A regarding "Constitution, Experience & Financial Standing" enclosed with the tender failing which their tender may be rejected. The bidders shall supply the names & address of the Directors of the firm, their income tax permanent account number, income tax return and turnover of the firm for the last three years and specific allied information as per enclosed annexures.

- Documents to be furnished must bear signatures of a person authorized as per constitution and composition of the firm. Authenticating documents to prove authority of signatory (Legal power of attorney in favour of signatory) must be attached with the Tender.
- Tenderers should submit their offer in unambiguous wording failing which PSTCL's interpretation will be final.
- Validity of offers must be for 120 days from the date of opening of tender.
- All the Annexures to the specification and requisite documents as per requirement of the specification must be duly filled / submitted in the 1st instant else the bid shall be rejected.
- PSTCL reserves the right to increase or decrease the quantity of material or to reject any or all the tenders without assigning any reason. PSTCL will not be held responsible for this and will not pay any expenses or losses that may be incurred by the tenderers in the preparation of tender.
- The bidders shall supply a list of two authorized person with their signatures duly attested on the firm's pad so that they may represent on behalf of the firm and participate in the opening process of the bids and the same should be with the authorized person(s), otherwise he / they will not be allowed to participate in the opening of tender.
- Negotiations, if necessary shall be held with the lowest tenderer only.
- Tenderer should not indicate any discount on rates mentioned in the Annexure of cost analysis. However qty/payment discount can be mentioned in the main tender itself. Tenderers offering discount on quoted price or after the opening of tender will be out rightly rejected.
- a) Earnest Money as per clause 14 of Part A of this specification may be deposited through a Demand Draft drawn in favour of Accounts Officer/CPC, PSTCL, Patiala.  
b) In case of Permanent Earnest Money Deposit (PEMD) of Rs 10.0 Lac (Rs. Ten Lacs) in the name of Chief Engineer/TS, PSTCL, Patiala, copy of a valid certificate to this effect, issued by the Accounts Officer/CPC, PSTCL, Patiala during three months immediately preceding the due date for tender opening and showing the Serial No. /Account No. allotted in the PEMD Register, with the bid documents should be submitted.
- **Only variable prices without any ceiling may be quoted.** A Certificate that only variable prices have been quoted in the tender must be given. Tenders with FIRM prices will not be entertained.

- The firms should not have been debarred, black listed or business dealings should not have been suspended shall also not be considered for opening of price bid.
- Offer of the firms who quote quantity less than 25 % of NIT quantity are liable to be rejected.
- The EMD clause of specification may be seen carefully. For the instant tender enquiry the requirement of EMD is as follows:

Sr. No.	Detail of E/W H/W fitting	100% EMD (Rs.)	Min.req. EMD (Rs.)	EMD for qty. 25% (Rs.)
1	Suspension clamp suitable for E/W size 7/3.15 mm	5200	5000	5000
2	4 R- Stock Bridge Dampers suitable for E/W size 7/3.15 mm	6700	5000	5000

The tenderer shall be required to submit Rs. 11,900/- (Rupees Eleven thousand nine hundred only) as earnest money as per clause 14 of General terms & conditions for full NIT qty. of the specification against this tender enquiry. In case a firm quotes for any individual item as listed above, it shall be required to deposit EMD for quoted item only.

**The quoted item of E/W Hardware fitting must be mentioned on the envelop Marked Part-I containing Demand Draft of EMD or the covering letter of EMD so that it may be checked that requirement of submission of minimum amount of EMD is met with or not.**



**PART-A**  
**GENERAL AND COMMERCIAL REQUIREMENTS**

**1. GENERAL INSTRUCTIONS TO BE OBSERVED BY BIDDERS.**

- All Bidders must carefully observe the following instructions. Bids not strictly in accordance with these instructions will be liable to be rejected:
- The bid must be complete in all respects. Every clause should carefully be studied in order to ensure submission of a complete and comprehensive bid. Failure to comply with any of these instructions is likely to render effective comparison of the tenders as a whole impossible and may lead to rejection of an otherwise competitively lowest offer.
- i) The tender must be complete in all respects. The following points should carefully be studied in order to ensure submission of a complete and comprehensive tender. Failure to comply with any of these instructions or to offer brief explanation for non compliance is likely to render effective comparison of the tenders as a whole impossible and may lead to rejection of an otherwise competitively lowest offer.
- ii) Tenders shall be submitted in duplicate and all copies shall be separately tagged and clearly marked as 'Original' and 'Duplicate' as the case may be.
- iii) Telegraphic quotations will not be accepted.
- iv) The tenders shall be submitted in three parts i.e. Part-I, Part-II & Part- III. Each part shall be enclosed in a separate envelope duly super scribed on the envelope as Part-I Earnest money, Part-II Technical/Commercial bids & Part-III-Price bids. All the three envelopes will be further enclosed in a larger envelope. **Quotation of each & every item shall be given / made separately and shall be enclosed in a separate envelope for each item duly super-scribed with the name of the item quoted on each envelope.** This will mean that tenderer giving bids for the two tendered items shall submit two envelopes, one for each item, sealed separately but enclosed in one envelope marked as "Price Bid."

**Any bidder, who quotes/mentions its price bid for more than one item on same piece/sheet of paper, shall be considered as violation of the above stipulation and such offers shall be liable to be rejected.**

The following procedure will be adopted for the opening of tenders.

- a) **Part-I - Earnest Money: The first part will consist of earnest money deposit in the form of demand draft in favour of AO/CPC, PSTCL, Patiala.**
- b) **Part-II- Technical /Commercial bids: The second part will consist of technical specification schedule of deliveries and all other terms and conditions EXCEPT RATES. (Annexure-A must be filled without rates for this part). All commercial terms including discount if any, Excise duty, CST/VAT, etc. shall be specified in the Part-II of the bid, so that any ambiguities relating to General**

**Terms & Conditions and Technical details can be sorted out before the opening of Part-III i.e. Price Bid.**

- c) Part-III: Price Bids: The third part will consist of the quoted prices for each items as well as other related terms like freight, insurance, ED, CST/VAT and other incidental relevant to the price. No correspondence/clarifications shall be entertained after the opening of Part-III.**

First the main envelope containing the bids will be opened in the presence of the bidder's representatives who choose to be present at the time, date and at the addressed named as above. After opening the main envelop, the envelope marked Part-I (earnest money) shall be opened first and if the earnest money is found to be as per the requirement of the specifications, only then the envelope marked Part-II shall be opened. The bids without earnest money shall be out rightly rejected.

After opening Part-II of the bids (technical/commercial), the bids will be technically & commercially evaluated by PSTCL. The third part of the bids (Price Bid) shall be opened in case of only those firms whose part-II of the bids after evaluation is found to be conforming to the specifications. The date and time for opening Part-III of the bids will be intimated to the qualifying firms. The price bids (Part-III) will be opened in the presence of the representative of the qualifying bidders who choose to attend.

- v) Offers/tenders should positively reach before the stipulated time and on the last date prescribed for their receipt. Those received late will not be considered / opened regardless of the date of posting of the tender.
2. The purchaser reserves the right to modify the "schedule of requirement", technical particulars and the specifications at any time and to place the order as a whole or in parts and to reject any or all the tenders received without assigning any reason. The Purchaser will not be responsible for and will not pay for expenses or losses that may be incurred by the tenderer in the preparation of the tenders.
  3. Quotation/Tenders should be enclosed in double covers both addressed to the Dy. CE/TS (Design), PSTCL, 1<sup>st</sup> floor, Shakti Sadan, Patiala. Both (inner & outer) covers shall be sealed and **super scribed with Tender Notice together with the date on which the tender is due and the items of material covered.**
  4. Quotations/Tenders shall be received in the office of the Dy. CE/TS Design PSTCL, 1<sup>st</sup> floor, Shakti Sadan, Patiala up to 11.00 Hrs. on the due date given in the tender notice and shall be opened at 11:30 Hrs. on the same day in the presence of Tenderer or their authorised representative who may like to be present. In case the due date of opening tenders happens to be a holiday tenders shall be received and opened at the same time on the next working day.

## 5. GENERAL TERMS AND CONDITIONS:

### 5.1 PRICES:

The rates should be quoted FOR destination at any Railway Station in Punjab/ PSTCL Railway siding wherever existing or delivery at PSTCL's Stores, through road transportation which will be treated at par with FOR destination, The breakup of the FOR destination price should be given as under: -

- a) The Ex-works rate of material inclusive packing and forwarding part of production cost.
  - b) Packing cost not forming part of production cost, handling cartage etc. Freight charges and transit risk insurance covered in FOR destination price.
- 5.2 All taxes and duties leviable on the price of finished goods per sub-clause 5.1

(a) Shall be paid extra and the same should be shown separately as prevalent on the date of opening of tenders, to be paid at the rate as may be actually prevalent at the time of supply otherwise these elements shall be deemed to be included in the quoted prices and will not be extra. No taxes and duties will be payable on the element of cost quoted under sub clause-5.1

(b) In addition to the break up of total price i.e. Ex-works cost, ED, CST, F&I and packing the bidder should also give split up of Ex-works price. The break up to prices shall be indicated in respective Performa attached with spec. The filling up of Performa shall be mandatory for tenderers. The split up of Ex-works prices shall indicate cost of raw material, labour component and overhead expenses. Raw material can further be divided into 3-4 parts depending on type of material. The Performa for Price schedule should be duly typed & Hand written prices shall not be accepted. These stipulations shall be highlighted in tender spec. & Special note in this regard shall also be appended in Price schedule Performa. Initially the cost can be worked out by either comparison with existing rates/market price or any other feasible means and thereafter this price should be regularly updated in accordance with relevant indices, just to have the rough estimate of market prices.

The Bidders should not be allowed to indicate overall discount on quoted price for which split up has been given. However quantity / payment / discount can be given by tenderer in the main tender (i.e. part relating to general terms & conditions). Any firm offering discount on the quoted price or after the opening of tender will be out rightly rejected.

5.3 In case of rates ex-works/ex-godown and for imported material, freight charge transit risk insurance, handling and clearance charges, FOB and C.I.F

5.4 **Only variable prices without any ceiling as per latest IEEMA circular may be quoted.** A certificate that only variable prices have been quoted in the tender must be given separately in part-II of the bid. Tenders with '**FIRM Prices**' will not be entertained. Price variation shall be allowed only on components of raw material as per clause price variation provided herein after.

- 5.5 The Bidder should quote their prices after taking into account benefit of MODVAT scheme available to them.
- 5.6 The rates quoted F.O.R. destination or ex-works should be given in both figures and words and should be duly typed. Any overwriting, erasion, cutting etc. should be in typed form. It should be legibly signed or avoided. Offers/tenders written pencil/handwritten shall be ignored.
- 5.7 VAT: The implication and % age (prevalent rate) of VAT levied on the prices may be clearly brought out.

**IMPORTANT:**

Those firms who do not give breakup of their rates as per requirement of specification shall not be considered. Rates of E.D., C.S.T & VAT, applicable must be indicated separately. All tenders should note that the price bids not indicating Ex-works including packing and forwarding charges forming cost of production, freight and insurance charges applicable, E.D., C.S.T/ VAT may be liable for summary rejection.

6. **PRICE VARIATION:**

- 6.1 Prices quoted must be "variable". Prescribed formula for plus / minus variation on the base price of component elements as prevailing on the first working day of the calendar month one month prior to the date of tender opening should form the basis for quoting variable rates. However, price adjustment shall be made on corresponding rates of variable elements prevailing on the first working day of calendar month, two months before the date of inspection call in case the material is within contractual delivery period. In case the material is delivered beyond the contractual delivery period, the price adjustment shall be made on the corresponding rates of variable elements prevailing on the first working day of calendar month, two months before the date of inspection call or the last date of the contractual delivery period whichever shall work out to be lower. Wherever the prices of raw material are controlled by the Government, the basis shall be Government Notifications from time to time.
- 6.2 Documentary proof of the base price on which the quoted rates of raw material have been based may be enclosed with the tender.
- 6.3 If statutory variation in CST/ VAT, ED or other levies declared by the Govt. are to be claimed on the raw material, it shall be indicated specifically.

6.4 **PRICE VARIATION CLAIMS:**

- 6.4.1 No variation or increase in prices will be allowed on consumables, handling, transportation, freight & insurance charges.
- 6.4.2 Unless otherwise authorized by the purchaser on the basis of consideration having been given to the force-majeure conditions resulting in delay in dispatches, no claim on price variation shall be entertained in respect of period falling beyond the contractual delivery period, if the material is supplied late. For this purpose the price variation will also include the increase in the statutory levies like ED, CST etc. However the benefit due to any decrease in price of raw material rates or statutory levies in respect of the period beyond the contractual delivery period shall be passed on to the purchaser.

If the variation is to be claimed along with the bills to be submitted through the Bank, the supplier shall submit their claim supported by relevant price circulars of IEEMA to CCF/CPC, PSTCL, Patiala well before actual dispatch of material, submission of documents through Bank under intimation to this office for verification of variation claims & to get the same approved before sending documents through Bank.

## 6.5 PRICE VARIATION FORMULA

Any increase or decrease in cost of raw material, and all India average consumer price index Number for industrial workers as per IEEMA formula(s) circulated vide memo No. IEEMA/PVC/TL-A&H/2001(R-2) effective from 1st March, 2011.

The formulas are given below:-

- (A) Transmission line accessories and hardware containing both aluminium and steel:

$$P = \frac{P_o}{100} (20 + 40 \frac{AL}{Alo} + 5 \frac{Zn}{Zno} + 20 \frac{SBI}{SBlo} + 15 \frac{W}{Wo})$$

- (B) Transmission line accessories and hardware containing only Aluminium:

$$P = \frac{P_o}{100} (20 + 65 \frac{AL}{Alo} + 15 \frac{W}{Wo})$$

- (C) Transmission line accessories and hardware containing only steel

$$P = \frac{P_o}{100} (20 + 58 \frac{SBI}{SBlo} + 7 \frac{Zn}{Zno} + 15 \frac{W}{Wo})$$

**wherein,**

P = Price payable as adjusted in accordance with the above formula.

Po = Price quoted/confirmed.

ALo = Price of EC Grade Aluminium Ingots (refer notes)

This price is as applicable on the 1st working day of the month, one month prior to the date of tendering.

Zno = Price of Electrolytic high grade zinc (refer notes)

This price is as applicable on the 1st working day of the month, one month prior to the date of tendering.

SBlo = Price of Steel Billets (refer notes).

This price is as applicable on the 1st working day of the month, one month prior to the date of tendering.

Wo = All India average consumer price index number for industrial workers, as published by the labour Bureau, Ministry of Labour, Govt. of India (Base:2001=100)

This index number is as applicable on the first working day of the month, three months prior to the date of tendering.

For example, if date of tendering falls in October, 2011, the applicable prices of Aluminium (AL<sub>0</sub>) zinc (Zn<sub>0</sub>) and Steel Billets (SBI<sub>0</sub>) should be for the month September, 2011 and all India average consumer price index number (W<sub>0</sub>) should be for the month of June 2011.

The above prices and indices are as published by IEEMA vide circular reference number IEEMA (PVC)/TLA&H (R-2)/ prevailing as on first working day of the month i.e., one month prior to the date of tendering.

**If the price variation formula is changed, the same shall be applicable for the price variation. During the transit period when both old and new indices are being circulated, then the admissible price variation shall be applicable, which is advantageous to PSTCL.**

AL = Price of EC Grade Aluminium ingots (refer notes)

This price is as applicable on the 1st working day of the month, two months prior to the date of delivery.

Zn = Price of Electrolytic high grade zinc (refer notes)

This price is as applicable on the 1st working day of the month, two months prior to the date of delivery.

SBI = Price of Steel Billets (refer notes)

This prices are as applicable on the 1st working day of the month, two months prior to the date of delivery.

W = All India average consumer price index number for industrial workers, as published by the Labour Bureau, Ministry of Labour, Govt. of India (Base : 2001 =100)

This index number is as applicable on the first working day of the month, four months prior to the date of delivery.

For example, if date of delivery falls in July 2012, the applicable prices of Aluminium (AL), Zinc (Zn) and Steel Billets (SBI) should be for the month May, 2012 and all India average consumer price index number (W) should be for the month of February, 2012.

The date of delivery is the date on which the material is notified as being ready for inspection/dispatch (in the absence of such notification, the date of manufacturer's dispatch note is to be considered as the date of delivery) or the contracted delivery date (including any agreed extension thereto), whichever is earlier.

- Note:
- a) All prices of raw materials are exclusive of modvatable excise/CV duty amount and exclusive of any other central, state of local taxes, octroi etc.
  - b) All prices are as on first working day of the month.
    - The details of prices are as under:-
    - The price of Aluminium (in Rs./MT) is the average price of EC grade Aluminium ingots as quoted by the primary producers of Aluminium as per IS:4026-1987.

- The price of Electrolytic high grade zinc (in Rs./MT) is ex-works price as quoted by a primary producer of zinc.
- The price of Steel Billet is the average price of Billets of size 100mm of all cities in Rs/MT, as published by Joint Plant Committee (JPC), Kolkata.

## 7 **MODVAT/CENVAT:**

The rates should be quoted after taking into account the MODVAT/CENVAT benefit accruing to the bidder, which will be retrained by him. However, the extent of MODVAT/CENVAT benefit available which has been taken into account while quoting the prices must be indicated. Any increase or decrease in this benefits due to change in policy of Govt. shall be passed on the purchaser or borne by it.

### 7.1 **COMPLETENESS OF TENDER:**

The bids must be complete in all respects. The bidder in his own interest should submit complete tender, as incomplete bids may prove disadvantageous to the bidder and they are liable to be rejected.

### 7.2 **VALIDITY:**

**The offer should be unconditionally valid for at least a period of Four Months (120 days)** from the date of opening of the tender. Withdrawal or modification of the offer shall not be permitted. Any bidder revising the offer within validity period is likely to be blacklisted.

## 8. **TERMS OF PAYMENT:**

“100% payment of the contract value pro-rata for each consignment of operationally complete equipment dispatched after approval of Inspecting Authority/Test Certificate etc. alongwith 100% Sales Tax, Excise Duty and other statutory levies as per contract shall be paid within 30 days against receipted challan subject to furnishing a Bank Guarantee of 5% of the amount valid for a period of three months after receipt of material/equipment against that consignment.

In case BG is not submitted in time as per PO, 5% payment in lieu thereof shall be withheld from the presented bill. The BG for 5% amount (or the 5% amount withheld in lieu of 5% BG) shall be released on satisfactory adjustment of Goods Receipt Note to be issued by consignee within the validity period of the said BG.

## 9. **DELIVERY SCHEDULE:**

- 9.1 The offer should clearly indicate monthly/ quarterly schedule of deliveries, date of Commencement and completion of supply against that indicated in the Notice Inviting Tender/ Specification which should normally cover period for entire job of manufacture, testing, inspection and supply after acceptance and shall be reckoned from the date of dispatch in case of Rail transport and receipted Challan / goods

receipt in case of road transportation by goods Carriers. Purchase order shall be placed strictly on the above under standing. Ex-stock and quicker deliveries may be sometimes preferred keeping in view the requirement of works.

- 9.2 The firm shall give FIRM delivery schedule while quoting. If the firm fails to supply the material within committed delivery schedule then it will likely to be not considered for subsequent orders. The purchaser reserves the right to divide the tendered quantity to have material as per specification. In case the order is placed on more than one firm, the delivery may be changed on pro-rata basis.

**10. PENALTY/DAMAGES FOR DELAY IN DELIVERY:**

If the supplier fails to deliver the material/equipment within the stipulated delivery period of the Purchase Order/Contract, the same is liable to be rejected and if accepted, the supplier shall be liable to pay as penalty charges, a sum of 0.5% (half of one percent) of the cost of undelivered supply / incomplete equipment per month of delay or part thereof, not exceeding maximum limit of 5% of the cost of complete unit of undelivered equipment so delayed. There will be a slack of one month that will not entail any penalty and will not involve any additional financial implication. Delay beyond slack period will attract penalty for the period of delay including slack period. However there will be no penalty, liquidated damages in respect of purchase of proprietary item.

**11. EXTENSION IN DELIVERY PERIOD:**

- 11.1 Any genuine delay in approval of technical details, drawings, samples, issuance of amendment of purchase order, conducting inspection and approval of inspection. Test Report/Test Certificates for allowing dispatch etc. will count towards extension of the delivery period by corresponding period other than admissible under Force Majeure conditions, if any substantiated by the supplier and duly accepted by the purchaser.

- 11.2 No extension in delivery shall be granted in case of delay in payment. However, for delayed payments beyond stipulated period as per terms of payment clause, compensation shall be credited @ 0.5% of the payment so delayed per month or part thereof to be adjusted against penalties levied or to be levied subject to a maximum of penalty livable due to delay in deliveries under the contract.

**12. NEGLIGENCE AND DEFAULT:**

- i) In case of negligence on the part of supplier/contractor to execute the order/contract with due diligence and expedition and to comply with any reasonable orders given in writing by the Purchaser in connection with the Purchase Order/Contract or any contravention in the provisions of the Purchase order/contract, the Purchaser may give 21 days notice in writing to the supplier/contractor to make good the failure or neglect or contravention and if the supplier/contractor fails to comply with the notice within time considered to be reasonable by the purchaser, the purchaser may black list or suspend business dealings with the supplier/contractor for a specific period apart from forfeiture of security etc. The action taken under this clause will be notified to all the purchasing agencies & other Boards by the concerned purchasing authority of PSTCL.



- ii) Further in case of such default by the supplier/contractor, the purchaser may also suspend business dealing with the supplier/contractor apart from claiming reasonable compensation/damages forfeiture of security etc.

**13. FORCE MAJEURE:**

During the pendency of the contract/purchase order, if the performance in whole/part by either party or any obligation there under, is prevented/delayed by causes arising out of any war, hostility, civil commotion, acts of the public enemy, sabotage, fire, floods, explosions, epidemics or non-availability of Government controlled raw-material under order/Instructions of Central/State Government regulations, strikes, lockouts, embargo, acts of Civil /Military authorities or any other cases beyond their reasonable control, neither of the two parties shall be made liable for loss or damages due to delay or failure to perform the contract during the currency of Force Majeure conditions, provided that the happening is notified in writing (with documentary proof) within 30 days from the date of the occurrence.

The supplies shall be resumed under the contract as soon as practicable after the happening (event) ceases to exist.

**14. EARNEST MONEY:**

- 14.1 In case of open and limited tenders, the bidders shall be required to submit Earnest Money at the following rates in the form of Punjab State Transmission Corporation Limited Bank draft alongwith the tenders: -

<b>a) Tender value up to Rs. 50,000/- and spot tenders</b>	<b>Nil</b>
<b>b) Tenders valuing above Rs.50,000/- (other than spot tenders.</b>	<b>2% of estimated value of the tender rounded off to multiple of Rs.10/- on the higher side, subject to a Minimum Rs.5,000/- and a maximum of Rs.10 lac.</b>

**14.2 The following shall be exempted from depositing Earnest Money:**

- i) Suppliers having permanent Earnest Money of deposit Rs. 10.00 Lac with the TS organization. A certificate to this effect issued by the concerned Accounts Officer of the PSTCL, during three month immediately preceding the due date of tender opening and showing the Serial number/Account number allotted in the Permanent Earnest Money deposit register shall be submitted by the Bidders in the envelope for Earnest Money.

Permanent earnest money deposit of Rs.10 Lac shall be deposited by the Bidder/ suppliers Organization wise with only CE/TS i.e. Transmission Organization of PSTCL irrespective of the fact whether they have PEMD already deposited with other purchase organization of the PSTCL.

- ii) Sole Manufacturers/suppliers or Proprietary items.

- 14.3** Earnest Money may be accepted in the form of Bank Guarantee valid up to 3 months after the validity date of tenders as NIT/Tender Specification in case of Public Sector Undertakings partly owned by Punjab Govt. /Central Government/Other State Govt.
- 14.4** In case of tenders not accompanied by full amount of Earnest Money for the items tendered but not less than 25% of the amount due, the order/contract, shall be awarded only for part of material/equipment services limited to a value corresponding to the actual amount of Earnest Money submitted with the tenders provided the placing of such part order is otherwise feasible and is in the interest of the PSTCL otherwise such tender shall be ignored.
- 14.5** Earnest Money shall be forfeited in case of withdrawal/Modification of an offer within the validity period as required in NIT/Tender Specification after opening of tenders.
- 14.6** In case of successful Bidders Earnest Money shall be converted as Security deposit and shortfall, if any shall be got deposited for faithful execution of Purchase Order/Contract.
- 14.7** In case of tenders not accepted, the earnest money shall be refunded within 30 days of the award of order/contract to the successful bidders.
- 14.8** Earnest Money may be deposited through a Demand draft drawn in favour of Accounts Officer/Centralized Payment Cell, PSTCL, Patiala.

Therefore a certificate to this effect issued by the AO/CPC, PSTCL, Patiala of the PSTCL under TS Organization during three months immediately proceeding the due date for tender opening and showing the serial Number/Account Number allotted in the PEMD Register shall be submitted by the Bidder in the envelope for Earnest Money, for seeking exemption thereof.

**15. INTIMATION TO ACCOUNTS OFFICER/CPC, CONSIGNEES:**

The supplier will have to intimate the probable date of dispatch followed by intimation regarding the actual date of R.R. to AO/CPC, PSTCL, Patiala, to enable him to arrange payment failing which demurrage/wharfage etc. will be to supplier's account. A copy of such intimation should be sent to the consignees and Chief Engineer/TS, 3<sup>rd</sup> floor, Shakti Sadan, PSTCL, Patiala also for reference immediately.

**16. SALE TAX:**

**16.1 (a) Value Added Tax:**

Implication of VAT may be clearly brought out. VAT shall be payable against documentary proof.

**(b) Central Sales Tax:**

The PSTCL has been registered as a dealer under the Central Sales Tax Act and the number is 03702075565.

When the Central Sales Tax is to be paid by the PSTCL, a declaration certificate in Form 'C' will be issued by the AO/CPC, PSTCL, Patiala on receipt of material.

When the tax is to be paid by the Supplier, a declaration certificate in Form will be issued by the AO/CPC, PSTCL, Patiala, subject to submission of the following certificates:

- i) Certified that the transaction on which tax has been claimed has been/will be included in the return submitted/to be submitted to the Sales Tax Authorities for assessment of the sales tax and the amount claimed from PSTCL has been paid to the sales tax authorities.
- ii) Certified that the goods, on which Sales Tax has been charged have not been exempted under Central Sales Tax Act or the Rules made thereunder and the charges on account of the sale tax on these goods are correct under the provision of the relevant Act or rules made thereunder.
- iii) Certified that we shall indemnify the PSTCL in case it is found at a later stage, that wrong/incorrect payment had been made on account of Sales Tax paid by us.
- iv) Certified that we are registered dealers under the Central State Sales Tax Act and our Registration No. is \_\_\_\_\_.
- v) Certified that payment has been made under protest. The bills for the Sales Tax and insurance charges, if any, should be submitted separately.

The firms indicating nil or concessional rate of CST / VAT will have to absorb the CST / VAT upto full rate applicable at the time of tendering. The firms who do not agree to this stipulation or indicate CST / VAT as extra without indicating the applicable rate shall be loaded with maximum rate for evaluation purposes.

## **17 EXCISE DUTY:**

17.1 Excise duty, if applicable, will be paid at rate(s) prevailing during the contracted delivery period on the basis of actuals. The following certificates shall have to be furnished alongwith invoice-cum-gate pass duly signed by the authorised agent/signatory. The first invoice should accompany the specimen signatures of the authorised signatory duly attested by the Managing Director of the factory with a copy of orders regarding his appointment as authorised signatory:-

- i) Certified that the transaction on which the Central Excise Duty is claimed has been/shall be included in the return submitted/to be submitted to the Central Excise Authorities and the amount claimed from the Board has been/shall be paid to Central Excise Authorities.
- ii) Certified that the goods on which ED has been charged have not been exempted under the Central Excise Act of the rules there under and the amount charged on account of ED on these goods is not additional than what is payable under the provisions of relevant act or the rules made there-under.
- iii) Certified that we shall indemnify the PSTCL in case it is found at a later stage that wrong or incorrect payment has been recovered on A/C of ED paid by us, further in case, an exemption for ED paid is agreed by Excise Authorities and ED amount is refunded to us, then equal amount shall be paid by us to the PSTCL to the fact ED has been charged from you & the amount so charged will be indicated.

- 17.2 In case the Excise Duty is applicable and is required to be paid extra as referred to Para-(17.1) above the bidder should clearly indicate the present rate (in-percentage) applicable to their company.
- 17.3 The maximum rate (in percentage) upto, which the Excise duty may become leviable /payable under the prevailing Rules & Regulations applicable to their company, should also be clearly indicated in their tender.
- 17.4 In case the Excise Duty is applicable/payable, necessary certificate of Excise duty claimed/ Excise Gate pass duly authenticated by the authorised representative of Central Excise Department, shall however be furnished by the supplier along with each consignment. The supplier should therefore, clearly indicate in their tender that whether such Excise Duty Gate Passes/ Certificates shall be furnished by them or not.
- 17.5 The firm indicating nil or concessional rate of Excise duty in their tenders will have to absorb Excise duty up-to the full rate applicable at the time of tendering.

**18. INSURANCE:**

- 18.1 The rates are required to be quoted on FOR destination basis and it is the responsibility of the supplier to deliver the goods in sound condition FOR destination and for that purpose the supplier may at his option insure the material against all risks at his own cost during transit for full delivered value of the material upto destination. All works in connection with making and settling of claims, if any, with Railway Authorities and or Insurance Company shall be carried out by the Contractor for which no extra payment shall be made by the Board. However, necessary assistance required in connection with making and settling of such claims, if any, shall be provided by the consignees.
- 18.2 All damages and/or shortages during transit as covered by the insurance shall be made good immediately on receipt of such information from the consignees without waiting for settlement of claim. However, in case of apparent damages and/or shortages, the consignee shall obtain the loss/damage certificate from the Railway authority and send the same to the Contractors within a period of thirty days from the date of receipt of material. The Supplier/ Contractors shall submit a certificate with each bill to the effect that the material has been duly insured.
- 18.3 The consignees shall report losses and damages to the firm within 30 days of arrival of the equipment at the site. It will, however, be supplier's responsibility to prefer timely claims on the insurance underwriters and to arrange replacement thereof the consignees.
- 18.4 The suppliers shall be wholly responsible for the loss, shortages, and damages etc. during transit, Such shortages and damages etc. will have to be replaced/repared by supplier/ contractor free of cost immediately without waiting for maturing of the Supplier's/Contractors claims with the Road Transport/Railway Authorities.
- 18.5 In case replacement/repair of defective material is not carried out within six months of intimation of damages, supplier shall have to pay interest at the rate of 12% per annum on the advance payments made by the Punjab State Electricity Board from the date of its payment upto the date of the re-commissioning of the equipment after replacement/repair or to the date the default is made good.

**19 WARRANTY:**

The supplier/Contractor shall be responsible to replace free of cost with no transportation and insurance expenses to the purchase up to the destination of

material/equipment, the whole or any part of the material; which under normal and proper use and maintenance, proves defective in material or workmanship within 12 months from the date, it is taken over by the purchaser or 18 months from the date of dispatch in respect of indigenous equipment, 24 months from date of shipment for imported material, whichever expires earlier, provided the Purchaser gives prompt written notice of such defects to the supplier/contractor. Such replacement shall be affected by the Supplier/Contractor, within a reasonable time not exceeding 6 months of the intimation of defects. Supplier's /Contractor's responsibility arising out of supply of material or its use whether on warranties or otherwise shall not in any case exceed the cost of correcting the defects or replacing the defective part/material and upon the expiry of the warranty period stipulated above, all such liabilities shall terminate.

The above provision shall equally apply to the material so replaced/repared by the supplier/contractor under this clause in case the same is again found to be defective within 12 months of its replacement /repair. In case replacement/repair of defective material is not carried out within six months of intimation of defects, the supplier/contractor shall have to pay interest @ 12% per annum on the value of each complete operational unit of equipment beginning from the date of becoming defective up to date of its recommissioning after replacement/repair.

**20. CHANGES:**

No variation or modification or waiver of any of the terms and provisions shall be deemed valid unless mutually agreed upon in writing by both the Purchaser and the Supplier.

**21. OCTROI CHARGES :**

Octroi charges shall be paid extra on actual basis if applicable.

**22. DISPATCH INSTRUCTIONS :**

The material will be required to be dispatched as per the dispatch instructions issued by the Purchaser.

**23. RAW MATERIAL:**

The raw material to be used in the manufacture of the goods/equipment's to be supplied against the Purchase Order/contract shall be of the best quality of its kind obtainable in the market. The supplier /contractor shall be solely responsibility for the procurement of raw material required for the purpose.

**24. SAMPLE:**

Samples must be supplied by the contractors/suppliers free of cost at the purchaser's office. Ordinarily samples will not be returned to the tenderer/supplier. However, expensive samples, the return of which is desired by the supplier/contractor, will be returned to him at his risk and cost.

**25. INSPECTION AND TEST:**

The PSTCL shall inspect, examine and test equipment/material through its officials and/or through an outside agency nominated by PSTCL at the manufacturer's/supplier's work, during or after the manufacture of goods prior to dispatch, on receipt of a clear notice of minimum two weeks in advance, to be reckoned from the date of receipt by purchaser. The supplier/contractor shall provide all facilities as may be required to carry out the tests in accordance with approved standards, free of cost. If the purchaser or the nominee representative desire to have one or all the tests to be got done through independent lab or test house, the charges of such lab/ test house shall be borne by the supplier. The chemical

- composition of the raw material can be got checked from the Govt. approved test labs as per relevant IS at the time of inspection
- 25.1 In case the inspection is waived off by the PSTCL, the supplier shall be required to submit test certificates in triplicate for approval. No material shall be dispatched without inspection and/or approval of test certificates unless so directed. Any material consumed during testing/ inspection shall be to supplier's account.

Random testing of material on receipt in the stores irrespective of the fact whether or not it was inspected before dispatch shall be carried out by PSTCL and in case of any failure the entire lot shall be rejected at the risk and loss of supplier. The supplier/contractor shall be required to furnish to the purchaser office/consignees where ever necessary the following documents alongwith the consignment.

i.	Printed Pamphlets/Catalogues	2 Copies
ii.	Instruction books	2 Copies
iii.	Drawing	2 Copies
iv.	Any other relevant information(to be incorporated at the time of placing the Purchase order)	2 Copies

In case the goods have not been inspected/tested at the manufacturer works by a representative of the PSTCL, the supplier/contractor shall furnish the following certificates alongwith consignment for facility of the consignees.

- a) Type test certificates
- b) Acceptance test certificates
- c) Routine Test Certificates

**26. CIVIL SUIT/JURISDICTION:**

All legal proceedings in connection with this purchase order/contract shall be subject to the territorial Jurisdiction of the local civil courts at Patiala only.

**27. ARBITRATION:**

- 27.1 If at any time, any question, dispute or difference, whatsoever, shall arise between the purchaser/PSTCL and the contractor/supplier, upon or in relation to or in connection with the P.O. /contract, either party may forthwith give to other, notice in writing of the existence of such question dispute or difference and the same shall be referred for sole arbitration of a nominee of the purchaser/PSTCL who shall give a reasoned/speaking awards. The award of the sole arbitrator shall be final and binding on the parties under the provision of the Indian Arbitration Act,1996 and of the rules there-under. Any statutory amendment, modification or re-enactment thereof for the time-being in force, shall be deemed to apply to and be incorporated in contract/P.O. It

will not be objectionable if the sole arbitrator is an officer of the PSTCL, and he has expressed his views on all or any of the matters in question of dispute or difference.

- 27.2 Upon every or any such reference, the cost of and incidental to the reference and award respectively, shall be the discretion of the Sole Arbitrator so appointed who may determine the amount thereof or direct the same to be taxed as between solicitor and client or as between party and party and shall direct by whom and to whom and in what manner the same is to be borne and paid.
- 27.3 The work under the contract shall, if reasonably possible, continue during the arbitration proceeding and no payments due or payable by the purchaser/ PSTCL shall be withheld on account of such proceedings.

## **28. CONSTITUTION EXPERIENCE AND FINANCIAL STANDING:**

The bidders should invariably supply the following information with the tenders: -

- 28.1 Constitution and composition of the firms:
- i) If a Joint Stock company, copy of its Memorandum and articles of Association and other particular.
  - ii) If a partnership, a copy of the partnership deed, particulars of partners.
  - iii) If a proprietary concern, the standing of the proprietor and if registered with the Register of Companies/Firms, their registration No.
- 28.2 Experience & standing in the market.
- 28.3 Particulars of purchase order/contracts executed with the board & other boards/government departments.
- 28.4 Financial position;
- i) Balance sheet for the last three years, including Trading, Manufacturing, profit and Loss Account.
  - ii) Bank references.

## **29 INFORMATION REGARDING LIST OF BANKERS THE PURCHASER DEALS WITH:**

The Punjab State Transmission Corporation Ltd., deals with the following Banks at Patiala.

- i) State Bank of Patiala, The Mall, Patiala.
  - ii) Punjab National Bank, The Mall, Patiala.
  - iii) Central Bank Of India, The Mall, Patiala.
  - iv) Bank of India, The Mall, Patiala.
  - v) United Commercial Bank, Old Kotwali Chowk, Patiala.
  - vi) Bank of Broda, Patiala.
  - vii) Punjab and Sind Bank, Patiala
  - viii) Oriental Bank of Commerce, Patiala
- 29.1 The Railway Receipt/Goods Receipt and invoices etc. should be sent to the authorities to be specified in the Purchase Order.
- 29.2 Any demurrage occurring as a result of sending Railway goods Receipt through a Bank other than the one with which the accounts of the Purchaser are operated will be to the account of the Supplier/Contractor.
- 29.3 No goods will be accepted by the consignees unless accompanied by challan or invoices.

**30. SECURITY DEPOSIT:**

The successful bidders shall be required to submit security deposit for faithful execution of the purchase order/contract at the rate of two percent (2%) of ordered value rounded off to a multiply of Rs.10/-on the higher side.

- 30.1 Ordinarily, in the case of successful bidders, the Earnest Money received with the tender shall be converted into security deposit. If the amount of earnest money received with tender falls short, the contractor/supplier shall be required to deposit the additional amount and in case of earnest money received with the tender is more than the amount of the security deposit required for purchase order/contract, the balance shall be refunded.
- 30.2 The bidders, having permanent deposit of Rs. Ten lac with Transmission Organisation' and hence exempted from depositing earnest money with tender, shall also be required to submit security deposit @ 2% of the ordered value in the form of cash/demand draft/Bank Guarantee (Annexure –C) within 30 days from the award of order/contract.
- 30.3 The following shall be exempted from depositing security against order/contract awarded to them:
- a) Public Sector Undertaking owned by Punjab Govt./Central Government/other state Govt. supplying material directly through Units owned by them. Exemption shall not be applicable for supply of material through private unit/manufacture.
  - b) Manufacturers/suppliers of proprietary items.
- 30.4 On faithful execution of purchase order/contract in all respects, including warranty period, the security deposit of the contractor/supplier shall be released by the purchaser.
- 30.5 In the event of default on the part of the contractor/supplier in the faithful execution of purchase order/contract, his security deposit shall be forfeited. The forfeiture of security deposit shall however, be without prejudice to any other rights arising or accruing to the PSTCL under relevant provisions of the purchase order/contract like penalty/damages for delay in delivery including suspension of business dealings with PSTCL for a specific period.

**31. CANCELLATION:**

The purchaser reserves the right to cancel the purchase order as a whole or in part at any time or in the event of default on the part of the supplier prior to the receipt of information regarding taking in hand of the manufacture of material against the Purchase order/despatch of material to the consignee.

**32. ORDER PREFERENCE:**

The PSTCL would allow an order preference to such Bidder whose works are situated within the State of Punjab as per the procedure laid down as under:

- 32.1 The rate of Punjab firms would be de-escalated by 15% for all the Units. For Punjab based firms up to 20% of total quantity can be reserved provided they fall in Consideration zone after application of price differential. For this purpose the merit position of Punjab firms shall be prepared separately, However where Punjab firms qualify amongst the lowest bidders in their own quoted rates they shall form part of the original quoted list for the purpose of placing orders.



- 32.2 The zone of consideration for placing of purchase order/contract would there after be demarcated taking into account the quantity of material required as per NIT and the quantities offered by the different bidders.
- 32.3 The purchase on the Punjab firm claiming order preference and falling within this zone would be placed on lowest rate of the firm not claiming order preference within the zone of consideration or on the concerned Punjab firms own quoted rate whichever may be lower.
- 32.4 The Punjab based firms claiming order preference shall be required to furnish an undertaking in prescribed form as Annexure-C of PSTCL Purchase Regulations, on a non-judicial stamp paper of appropriate value to the effect that they shall execute the order if placed on them under 'Order preference' as per tender specification. Such undertaking should be submitted by the Punjab based tendering firms latest by the close of the day of opening of the tenders. In case no such undertaking is furnished by the Punjab based firms who are otherwise eligible for claiming 'Order Preference' as per the tender specification, their tender shall not be considered for placement of any order under order preference. In the event of refusal by the Punjab based firms to execute the purchase order/contract at their quoted rates or offers made under order preference as per 32.2 and 32.3 above as the case may be, after having furnished the above undertaking their Earnest Money shall be forfeited apart from initiating further administrative action, such as suspending business dealings, blacklisting etc.

**33. CONTRACT AGREEMENT:**

The detailed order issued in accordance with agreed terms & conditions accepted/ acknowledged by the firm shall itself form valid contract along with subsequent amendment, if any, and shall be construed and operated as such in terms for of Indian Contract Act-1872 as amended up to date.

It will be obligatory on the part of the successful Bidder to execute within 30 days of the receipt of the detailed order, a legal Contract agreement on non-judicial stamp paper of appropriate value (Annexure –E). The detailed PO so issued shall be termed Purchase Order-cum-Contract Agreement. The Contract shall be made in duplicate and each party will retain one copy.

After execution of contract, contractor shall supply if required sufficient number or extra copies of contract, specification drawing/ drawings, technical literature, bill of material, as finally approved by the purchaser. The cost of these items shall be deemed to have been included in the tender price and the bidders will not be entitled to any extra payment on this account.

The bidder in the interest of execution of contract within stipulated time must offer his comments against each and every clause of this specification to which he does not agree so that decision could be taken by competent authority to all deviations. The clause, against which no comments are offered, shall be considered to have been agreed to by the bidder and shall have to be included in the contract agreement to be executed/signed by the successful bidder.

**34. Quantity Tolerance :**

A tolerance of (-) 2% of the ordered quantity subject to max. 20 nos. H/W fittings (of each H/W fitting taken separately in case order is placed for more than one type of H/W fitting) shall be allowed towards completion of supply of ordered quantity.

**35. Fake Inspection Calls/ Failure During Inspection**

If the firms do not get the material inspected when the inspecting officer visits their works after receipt of inspection call on one pretext or the other or the material fails during inspection, it will have to bear TA/DA for the journey performed by such an Inspecting officer, which shall be Rs.15,000/-(Outside Punjab) and Rs.5000/-(Within Punjab) per visit of each officer. Besides the recovery against each such fake call, a letter of warning shall be issued and it shall be counted towards firm's performance for all intents and purposes. These charges shall be Rs. 15000/- and Rs. 5000/- per visit of each officer respectively in case the material fails during inspection.

**36. Works Appraisal**

If some new firm submits tender who has never supplied the tendered item(s) to PSTCL earlier, its works appraisal shall be carried out before opening of Part-III (Price Bid) to ascertain whether the offer of the firm is technically / commercially acceptable or not. The cost of the works appraisal shall be borne by the firm and the same shall be deposited by the firm along with the tender.

The new firm, entering into business dealings with PSTCL shall attach a demand draft of requisite charges detailed below drawn in favour of AO/CPC, PSTCL Payable at Patiala along with the tender, failing which the offer of the firm shall not be processed further. The charges shall be Rs.50,000/- (for firms located outside Punjab) and Rs.25,000/- (for firms located inside Punjab). In case the works appraisal report is negative, these charges will be repeated for subsequent works appraisal.

**37. Submission of Documents for Expeditious payment**

In order to ensure expeditious payment of bills, the following may be followed:

1. The bills along with a copy of receipted challan must be submitted in the office of AO/CPC and this office simultaneously within a period of seven days from the date of receipt of the material
2. The following documents / information should also be supplied directly to AO/CPC in addition to this office.
  - i) Copy of Bank Guarantee.
  - ii) Copy of Inspection Call letter.
  - iii) Inspection report /waiver reference if any.
  - iv) Dispatch Instruction if separately given

Dy. CE /TS (Design)  
PSTCL, Patiala.

**PART-B****TECHNICAL SPECIFICATION FOR HARDWARE FITTINGS****1.0 Scope:**

- 1.1 This specification covers design, manufacture, testing, supply and delivery at destination on any Rail/Road head in Punjab of Hardware fittings and Accessories like Suspension Clamps and 4 R Stock bridge dampers suitable for Earth wire of Size 7/3.15mm.
- 1.2 Technical specification contained herein is for the guidance of the Bidders. Any deviation from Purchaser's specification will be considered on their relative merits in respect of performance, efficiency, durability and overall economy, consistent with the requirements stipulated herein after.
- 1.3 Equipment carrying ISI Mark would be preferred.
- 1.4 Manufacturers, who are not in a position to offer material strictly according to purchaser's specification, need not submit their offers.
- 1.5 Manufacturers who have genuine facilities to manufacture single piece forged fitting and galvanizing need only submit their offers.

**2.0 Standard**

- 2.1 The Hardware fittings for Earth wire shall conform to the following Indian Standards, which shall mean latest revisions, with amendments/changes, adopted and published, unless specifically stated otherwise in the Specification.
- 2.2 In the event of the supply of hardware fittings; accessories conform to standards other than specified, the Bidder shall confirm in his bid that these standards are equivalent to those specified. In case of award, salient features of comparison between the Standards proposed by the Contractor and those specified in this document will be provided by the Contractor to establish their equivalence.

<b>Sr. No</b>	<b>Indian Standard</b>	<b>Title</b>
1.	IS: 209-1979	Specification for Zinc
2.	IS: 1573-1976	Electroplated Coating of Zinc on Iron & Steel
3.	IS: 2121-1981 Part-I	Specification for Conductors and Earth wire Accessories for overhead power lines
	Part-II & III	Mid-Span Joints & Repair Sleeve for Conductors
4.	IS: 2486	Specification for Insulator Fitting for overhead power lines with nominal Voltage greater than 1000V
	Part-I, 1971	General requirements and tests

5	IS: 2629-1985	Recommended practice for Hot Dip Galvanizing of Iron and Steel
6.	IS: 2633-1986	Method of testing Uniformity of coating on Zinc Coated Articles.
7.	IS: 4826-1979	Galvanized Coating on Round Steel Wires
	IS: 6745-1972	Methods of Determination of Weight of Zinc Coating of Zinc Coated Iron and Steel Articles.
8	IS: 8263-1976	Method of Radio interference Tests on High Voltage Insulators
9.	IS: 6639-1976	Hexagonal Bolts for Steel Structures
10.	IS: 9708-1980	Specification for Stock Bridge Vibration Dampers for Overhead Power Lines

The above standards are available from Bureau Of Indian Standards, Manak Bhawan, 9, Bahadur Shah Zafar Marg, New Delhi –110001.

### 3.0 **List of orders**

Bidders who wish to participate in this tender enquiry will have to supply a list of orders executed by them during the last three years and copies of the latest order for the items quoted. List of orders for the item quoted which are pending with tenderer for execution, be also supplied.

### 4.0 **Technical Description/Detail of Hardware Fittings:**

- 4.1 The hardware fittings shall be as per the specification drawings enclosed with this part of the specification. Each hardware fitting shall be supplied complete in all respects and shall include the following hardware parts:
- 4.2 Suspension assembly to suit Earth wire of size 7/3.15mm.
- 4.3 Other necessary fittings such as Clamp body, Keeper Piece, U- Bolt eye Hook and suspension clamp keeper etc., Jumper terminal and U- Clevis etc. to make the hardware fittings complete.

### 5.0 **Corona and RI Performance:**

Sharp edges and scratches on all the hardware fittings shall be avoided. All surfaces must be clean, smooth, without cuts and abrasions or projections.

The Bidder must give suitable assurance about the satisfactory Corona and Radio Interference performance of the material offered by him.

### 6.0 **Raw Materials:**

- 6.1 The materials of the various components shall be as specified hereunder. However components made of alternative materials giving equivalent or better performance

shall also be considered. The Bidder shall indicate the material proposed to be used for each and every component of hardware fittings stating clearly the class, grade or alloy designation of the material, manufacturing process & heat treatment details and the reference standards.

- 6.2 Raw material to be used for the manufacture of various hardware fittings made of mild steel, forged steel and aluminium alloy, nuts and bolts, cotter pins, security clips, galvanizing or electro-plating shall conform to relevant Indian standard and may be tested by purchaser according to the tests laid therein.

## **7.0 MANUFACTURER**

- 7.1 The tender shall indicate the name of manufacturers in case of bought out items and shall not supply the material made by a manufacturer other than specified in the order, without prior approval of the purchaser. Information about manufacturer be given alongwith tender.
- 7.2 Manufacturer who are not in a position to offer material strictly according to purchaser's specification need not submit their offers.
- 7.3 Manufacturers who have genuine facilities to manufacture single piece forged fittings, and galvanising need only submit their offers.

## **8.0 Detail of Material/Processes**

### **8.1 Mild Steel:**

Raw material to be used for the manufacture of various hardware fittings made of mild steel shall be tested according to the tests laid in the relevant Indian standard, if so desired by the purchaser.

### **8.2 Forging:**

All the forged fitting shall be made from forged steel and all the tests specified in the corresponding IS shall be performed on the test bars, if so desired by the purchaser. The Bidder shall specify whether cold or hot process shall be used and the forging done with drop hammer or press, alongwith the size and capacity of the forging equipment. All the forged fittings shall be made out of one piece and these shall not be made by joining, welding or shrunk fitted or with any other process.

The forging shall be properly cleaned and visual inspection of the same can be made by the representative of the purchaser, if required, before releasing the same for galvanizing, after which sample test for galvanizing and Routine tests shall be performed for mechanical strength.

The Bidder shall indicate type of forging steel and its mechanical properties, which will be used for producing forged hardware fittings.

- 8.3 The Bidder shall state whether the material will be non-heat treated or heat-treated. If so desired by the purchaser all tests specified in IS-617/1959 with its latest

amendments shall be performed on the test specimen, which will be manufactured along with the fittings and heat treated along with them.

- 8.4 Split pins shall be made of tinned brass only. Circular flat washers shall be provided where locking with split pins is provided.
- 8.5 All parts of different fittings which provide for inter connection shall be made such that sufficient clearance is provided at the connection point to ensure free movement and suspension of the assembly.
- 8.6 All ferrous fittings shall be hot dip galvanized except spring washers which shall be electro galvanized and tests laid down in the relevant ISS shall be performed on galvanising.

#### **9.0 Drawings**

Semi-dimensioned drawings of each item are attached with the specification. As Guidance, the various parts of each item (accessory/fittings) should be same shape and arrangement as provided in the specimen drawings. No change on this account would be acceptable at a later stage.

The tenderer shall have to supply the dimensioned drawing of each component of all items with the tender in triplicate included in the specification. The tender will be dealt according to these drawings. Detail of material of which the fittings are made of and their breaking strength shall be indicated. Separate drawing for each item shall be submitted with complete dimensions.

Bids received without complete drawings/test certificates/Technical details shall be summarily rejected.

#### **10.0 TOLERANCE IN DIMENSION**

The tolerances in all important dimensions, if any, shall be indicated on the drawings separately, otherwise the purchaser shall stick to the tolerances dimensions given on the specification drawings, in case the offer is accepted.

The dimensioned drawings and other relevant information submitted along with the tender or agreed to by the purchaser and the successful tenderer subsequently, shall form the contract drawings and shall be referred to for inspection and testing of the material. It is stressed that no subsequent approval of the drawings should be asked for by the supplier. The supplier shall supply these drawings prepared on the tracing cloth with ink and or three copies of each drawings to each consignee and five copies to the purchaser before the commencement of supplies for records.

#### **11.0 Workmanship:**

- 11.1 All the equipment shall be of the latest design and conform to the best modern practices adopted in the Extra High Voltage field. The Bidder shall offer only such equipment as guaranteed by him to be satisfactory and suitable for 220 KV, transmission lines and will give continued good performance.

- 11.2 The design, manufacturing process and quality control of all the materials shall be such as to give the specified mechanical rating, highest mobility, elimination of sharp edges and corners, best resistance to corrosion and a good finish.
- 11.3 All ferrous parts including fasteners shall be hot dip galvanized, after all the machining has been completed. Nuts may, however, be tapped (threaded) after galvanizing and the threads oiled. Spring washers shall be electro-galvanized. The bolt threads shall be undercut to take care of the increase in diameter due to galvanizing. Galvanizing shall be done in accordance with IS: 2629-1985 and shall satisfy the tests mentioned in IS: 2633-1986. Fasteners shall withstand four dips while spring washers shall withstand three dips of one-minute duration in the standard preece test. Other galvanized materials shall be guaranteed to withstand at least six successive dips each lasting one (1) minute under the standard preece test for galvanizing unless otherwise specified.
- 11.4 Before ball fittings are galvanized, all die flashing on the shank and on the bearing surface of the ball shall be carefully removed without reducing the dimensions below the design requirements.
- 11.5 The zinc coating shall be perfectly adherent, of uniform thickness, smooth, reasonably bright, continuous and free from imperfections such as flux, ash, rust stains, bulky white deposits and blisters. The zinc used for galvanizing shall be grade Zn 99.95 as per IS: 209-1979.
- 11.6 Pin balls shall be checked with the applicable "GO" gauges in at least two directions, one of which shall be across the line of die flashing and the other 90° to this line. "NO GO" gauges shall not pass in any direction.
- 11.7 Socket ends, before galvanizing, shall be of uniform contour. The bearing surface of socket ends shall be uniform about the entire circumference without depressions or high spots. The internal contours of socket ends shall be concentric with the axis of the fittings as per IS: 2486.
- 11.8 The axis of the bearing surfaces of socket ends shall be coaxial with the axis of the fittings. There shall be no noticeable tilting of the bearing surfaces with the axis of the fittings.
- In case of casting, the same shall be free from all internal defects like shrinkage inclusion, blowholes, cracks etc. Pressure die-casting shall not be used for casting of components with thickness more than 5 mm.
- 11.9 All current carrying parts shall be so designed and manufactured that contact resistance is reduced to minimum & localized heating phenomenon is averted.
- 11.10 No equipment shall have sharp ends or edges, abrasions or projections and cause any damage to the conductor in any way during erection or during continuous operation, which would produce high electrical and mechanical stresses in normal working. The design of adjacent metal parts and mating surfaces shall be such as to prevent corrosion of the contact surface and to maintain good electrical contact under service conditions.
- 11.11 All the holes shall be cylindrical, clean cut and perpendicular to the plane of the material. The periphery of the holes shall be free from burrs.

- 11.12 All fasteners shall have suitable corona free locking arrangement to guard against vibration loosening.

## **12.1 SUSPENSION CLAMP FOR GSS WIRE 7/3.15MM**

Suspension clamp shall be as per details shown in drawing No.HW/TF-7305/R-1 free Centre type Salvi Design. The clamp body & keeper plate shall be made of Malleable cast iron duly HDG. The Eye Hook shall be HDG Forged steel.

The cotter pins shall be of brass and the spring washers shall be of spring steel duly Electro galvanized. All other ferrous components shall be Hot Dip Galvanized. The tenderers are required to submit details drawings of the individual parts and the assembly of the suspension clamp as given in Drg.No. HW/TF-7305/R-1.

## **12.2 4R-Stock Bridge Vibration Dampers suitable for GSS wire 7/3.15mm**

- 12.2.1 Vibration dampers of 4R-stockbridge type with four (4) different resonances spread within the specified aeolian frequency band width corresponding to wind speeds of 1m/s to 7 m/s shall be used at suspension and tension points on each conductor in each span to damp out aeolian vibrations as mentioned hereinafter. The 4R-stock bridge type vibration damper shall be as per details shown in drawing No. HW/TF-7341.
- 12.2.2 The clamp of the vibration damper shall be made of high strength aluminum alloy designation 4600 as per IS: 617-1994. It shall be capable of supporting the damper and prevent damage or chafing of the conductor during erection or continued operation. The clamp shall have smooth and permanent grip to keep the damper in position on the conductor without damaging the strands or causing premature fatigue failure of the conductor under the clamp. The clamp groove shall be in uniform contact with the conductor over the entire clamping surface except for the rounded edges. The groove of the clamp body and clamp cap shall be smooth, free from projections, sharp ends, abrasions, grit or other materials, which could cause damage to the conductor when the clamp is installed. Clamping bolts shall be provided with self-locking nuts and designed to prevent corrosion of threads of loosening in service.
- 12.2.3 The messenger cable shall be made of high strength galvanized stranded steel with a minimum strength of 135 Kg/mm<sup>2</sup> having quality to prevent subsequent drop of weight and to maintain consistent flexural stiffness of the cable in service. The number of strands in the messenger cable shall be 19.
- 12.2.4 The damper mass shall be made of Cast iron hot dip galvanized alloy. All castings shall be free from defects such as cracks, shrinkage, inclusions and blowholes etc. The surface of the damper masses shall be smooth. The bidder should indicate the composition of the material so used for casting and give its ultimate tensile strength.
- 12.2.5 The damper mass shall be so designed so as to avoid accumulation of rainwater in it.
- 12.2.6 The damper clamp shall be cast over the messenger cable and offer permanent grip on it. The clamping bolts shall be provided with suitable locking devices to prevent loosening during service due to electrical and mechanical stresses.
- 12.2.7 The threads in nuts & tapped holes shall be cut after galvanizing and shall be well lubricated or greased. All other threads shall be cut before galvanizing.
- 12.2.8 Nuts and bolts should be workable with ordinary D.E. spanners.
- 12.2.9 The messenger cable shall not slip out of the grip at a load less than the mass pull-off value of the damper. The damper masses made of material other than zinc alloy shall



be fixed to the messenger cable in a suitable manner in order to avoid excessive stress concentration on the messenger cables, which shall cause premature fatigue failure of the same. The messenger cable ends shall be suitably and effectively sealed to prevent corrosion. The damper mass made of zinc alloy shall be casted over the messenger cable and have sufficient and permanent grip on the messenger cable under all service conditions.

- 12.2.10 The damper assembly shall be so designed that it shall not introduce radio interference beyond acceptable limits.
- 12.2.11 The vibration damper shall be capable of being installed and removed from energized line by means of hot line techniques. In addition, the clamp shall be capable of being removed and reinstalled on the conductor at the designated torque without shearing or damaging the fasteners and conductor.
- 12.2.12 The manufacturer must indicate the clamp bolt tightening torque to ensure that the slip strength of the clamp is maintained between 2.5 KN and 5 KN. The clamp when installed on the conductor shall not cause excessive stress concentration on the conductor leading to permanent deformation of the conductor strands and premature fatigue failure in operation.
- 12.2.13 The vibration damper shall not have magnetic power loss more than 1 watt at 500 Amps, 50 Hz alternating current per conductor.

The vibration analysis of the system, with and without damper and dynamic characteristics of the damper shall have to be submitted by the bidder along with his bid.

- 12.2.14 The technical particulars for damping design of the system are as follows:

Sr. No.	Description	Technical Particulars
		Earth wire 7/3.15mm
1.	Earth wire dia.	9.45mm
2.	No. of strands	7/3.1.5mm
3.	Ultimate Breaking load.	5710 Kg
4.	Span length in meters (a) Average span (b) Maximum span	310-350 meters 450-650 meters
5.	Tensile load in max. working tension At(-)2.5 <sup>o</sup> C & 2/3 full wind a) Max. working tension At(-)2.5 <sup>o</sup> C & nil wind b) Max. working tension at 32 <sup>o</sup> C & full wind	2050 Kg 1023.4Kg 880.0 Kg
6.	Max. Working temp.	75 <sup>o</sup> C

- 12.2.15 The Bidder shall submit the damper placement chart for spans ranging from 100 meters to 500 meters. Placement charts should be duly supported with relevant technical documents and sample calculations.

- 12.2.16 The damper placement charts shall include the following: -

- (i) Location of the dampers for various combinations of spans and line tensions clearly indicating the number of dampers to be installed per span.

- (ii) Placement distance clearly identifying the extremities between which the distances are measured.
- (iii) Placement recommendation depending upon type of suspension clamps (viz Free center type)
- (iv) The influence of mid span compression joints and repair sleeves in the placement of dampers.

**GENERAL REQUIREMENT FOR TESTS:**

**13.0 Tests and Standards:**

**13.1 Tests:**

The type, acceptance and routine tests and tests during manufacture shall be carried out. For the purpose of this clause:

- 13.2 Type tests shall mean those tests, which are to be carried out to prove the design process of manufacture and general conformity of the material to this Specification.
- 13.3 Acceptance test shall mean those tests, which are to be carried out on samples taken from each lot offered for pre-despatch inspection for the purpose of acceptance of that lot.
- 13.4 Routine test shall mean those tests, which are to be carried out on each item of the material to check requirements, which are likely to vary during production. Every test shall be performed in the presence of an authorized representative of purchaser and Bidder shall have to give intimation of the place, date, time and detail of each test to be carried out, to enable the purchaser to depute its representative to witness the test. If the purchaser decides to accept certificates of routine tests carried out by the supplier, the same shall be got approved before despatch of the material.
- 13.5 Tests during Manufacture shall mean those tests, which are to be carried out during the process of manufacturing and end inspection by the Purchaser to ensure the desired quality of the end product to be supplied by firm.
- 13.6 The standards & norms to which these tests shall be carried out are listed against them. The supplier shall perform all the tests specified in this specification or laid down in the relevant standard to which the material offered conforms including the type tests required therein so as to perform before or after the placement of the order, without any extra cost. All the arrangements for testing the material i.e. conductor, ground wire, compression dies, insulators etc. required for testing shall be arranged by the supplier at his own cost. Unless otherwise directed, no material shall be dispatched in the absence of purchaser's representative.
- 13.7 For all type and acceptance tests, the acceptance values shall be the values guaranteed by the Bidder in the data requirement sheets of this proposal or this acceptance value as specified in this specification, whichever is more stringent for that particular test.

**14.0 Type tests:**

The Bidder shall submit copy of the type test certificates carried out from independent approved test house in respect of each item made from the material specified and

according to the detail dimensions indicated on the drawing accompanying the tender, conforming to the type of material of which the concerned item was made of. In case of fitting the ultimate load at which the same failed may also be indicated. The type tests should be carried as per the relevant ISS and the test certificates should not be more than 5 years old from the date of opening of tender.

The Bids received without following Type Tests are liable to be rejected.

<b>14.1</b>	<b>Suspension Clamp Suitable for Earth wire of Size 7/3.15mm</b>	
a)	Visual Inspection	IS-2121(PART-III): 1992
b)	Verification of Dimensions	“
c)	Slip strength test for dead-end assembly	“
d)	Mechanical Strength test	“
e)	Chemical Composition test	“
f)	Galvanizing test	IS-2633

<b>14.2.</b>	<b>4R SB Damper suitable for E/W of size 7/3.15mm</b>	
a)	Visual Inspection	IS:9708 (Part-3):1993
b)	Verification of Dimensions	“
c)	Resonance frequency Test	“
d)	Fatigue tests	“
e)	Mass Pull off Test	“
f)	Dynamic characteristics test	“
g)	Damping efficiency test	“
h)	Clamp Slip Test	“
i)	Clamp Bolt Torque Test	“
j)	Magnetic power loss test	“
k)	Galvanizing/Electroplating tests	IS:2633

## **15.0 Acceptance Tests:**

The acceptance tests shall be performed on each type of Hardware fitting as per relevant ISS with latest amendment(s), if any or relevant standard tests specified in specification & the sample will be selected from the lot and the criteria for accepting or rejecting the lot shall be followed as laid down in relevant ISS.

<b>15.1</b>	<b>Suspension Clamp Suitable for Earth wire of Size 7/3.15mm</b>	
a)	Visual Inspection	a)
b)	Verification of Dimensions	b)
c)	Slip strength test for dead-end assembly	c)
d)	Mechanical Strength test	d)
e)	Chemical Composition test	e)
f)	Galvanizing test	f)

<b>15.2</b>	<b>4R SB Damper suitable for E/W of size 7/3.15mm</b>	
a)	Visual Inspection	IS:9708 (Part-3):1993
b)	Verification of Dimensions	“
c)	Resonance frequency Test	“
d)	Fatigue tests	“
e)	Mass Pull off Test	“
f)	Dynamic characteristics test	“
g)	Damper efficiency test	“
h)	Clamp Slip Test	“
i)	Clamp Bolt Tightening Test	“
j)	Magnetic power loss test	“
k)	Galvanizing/Electroplating tests	IS:2633

**16.0 Routine Tests:**

The routine tests of visual checking and mechanical testing for load shall be performed on each fitting before the same is accepted or released for dispatch. Each hardware fitting shall be tested for 50% of its failing load. The other fittings shall be tested as per relevant ISS. The routine tests shall be carried out as per relevant ISS.

**16.1 Testing Expenses:**

For tests which involve the tests on the complete insulator string with hardware fittings, the Contractor shall have to arrange to supply the necessary number of insulators & sets of hardware fittings (if required) at the place of testing free of cost.

In case of failure of complete insulator string in any type test, the Contractor shall get the test repeated at his cost.

**16.2 Testing and Additional Tests:**

The Purchaser reserves the right of having at his own expense any other tests(s) of reasonable nature carried out at Contractor's premises, at site or in any other place on addition to the aforesaid type, acceptance and routine tests to satisfy himself that the material comply with the specification.

The Purchaser also reserves the right to conduct all the tests mentioned in this specification at his own expense on the samples drawn from the site at Contractor's premises or any other test centre. In case of evidence of non compliance, it shall be binding on the part of Contractor to prove the compliance of the items to the technical specification by repeat tests, or correction of deficiencies, or replacement of defective items all without any extra cost to the Purchaser.

**16.3 Tests Reports:**

Copies of Type test reports shall be furnished along with the Bid.

Record of routine test report shall be maintained by the Contractor at his works for periodic inspection by the Purchaser's representative.

Test Certificates of tests during manufacture shall be maintained by the Contractor. These shall be produced for verification as and when desired by the Purchaser.

**17 Inspection:**

The Purchaser's representative shall at all times be entitled to have access to the works and all places of manufacture, where the material and/or its component parts shall be manufactured and the representatives shall have full facilities for unrestricted inspection of Contractor's, sub-Contractor's works, raw materials, manufacturer's of all the material and for conducting necessary tests as detailed herein.

The material for final inspection shall be offered by the Contractor only under packed condition. The engineer shall select samples at random from the packed lot for carrying out acceptance tests.

The Contractor shall keep the Purchaser informed in advance of the time of starting and of the progress of manufacture of material in its various stages so that arrangements could be made for inspection.

Material shall not be dispatched from its point of manufacture before it has been satisfactorily inspected and tested, unless the inspection is waived off by the Purchaser in writing. In the latter case also the material shall be dispatched only after all tests specified herein have been satisfactorily completed and tests reports must be supplied.

**18 Packing and Marking.**

All material shall be packed in strong and weather resistant wooden cases/crates. The gross weight of the packing shall not normally exceed 50 Kg to avoid handling problems.

The packing shall be of sufficient strength to withstand rough handling during transit, storage at site and subsequent handling in the field.

Suitable cushioning, protective padding, dunnage or spacers shall be provided to prevent damage or deformation during transit and handling.

Bolts, nuts, washers, cotter pins, security clips and split pins etc. shall be packed duly installed and assembled with the respective parts and suitable measures shall be used to prevent their loss.

All the packing cases shall be marked legibly and correctly so as to ensure safe arrival at their destination and to avoid the possibility of goods being lost or wrongly dispatched on account of faulty packing and faulty or illegible markings. Each wooden case/crates shall have all the markings stenciled on it in indelible ink.

The fitting made of extrusions shall have the following identification mark embossed/punched on these and those made of forged mild steel shall be stamped

marked wherever possible. Castings and Forging which shall be done at works other than that of the supplier shall bear identification mark, both of the manufacturer and supplier.

- Name and trade mark of the manufacturer.
- Size of the conductor for which it is to be used.
- Month & year of manufacture.

**19.0 Nut and Bolts:**

For all type of fittings for dip galvanized steel nuts and bolts only of reputed firm/ make or preferable ISI marked shall be provide /mentioned in the drawing.

**20.0 Guaranteed Technical Particulars:**

Complete technical particulars to be guaranteed by the Bidder shall be furnished as per Annexure- K-1 to K-2.

**21.0 SAMPLE:**

Samples must be supplied by the contractors/suppliers free of cost at the purchaser's office. Ordinarily samples will not be returned to the tenderer/ supplier. However, expensive samples, the return of which is desired by the supplier/contractor, will be returned to him at his risk and cost and shall be collected within one month of opening of tender.

**DELIVERY:**

Commencement : Half of material within one and half month from the date of receipt of P.O.

Completion : Rest within one and half month thereafter.

Note : i) Early supply may be taken keeping in view the requirement of works.

i) Delivery may taken as per requirement of works

However, the purchaser reserves the right to divide the tendered quantity to have material as per requirement. In case the order is placed on more than one firm, the delivery period shall be changed on pro-rata basis.

Dy. CE /TS (Design),  
PSTCL, Patiala.

## Annexure-A

**PRICE SCHEDULE****ATTENTION BIDDERS: PLEASE COMPLY WITH IMPORTANT NOTES FOR GUIDANCE OF BIDDERS.**

The Performa corresponding to each item must be filled invariably along with the detailed tender. If any item is not applicable that must be filled with words 'N.A.'. The interpretation of this office shall be final if information on any item is left blank.

Tender Enquiry No. : STQ- 4005  
 Name of the Tender : Hardware Fitting and Accessories Suitable for E/W of Size 7/3.15mm  
 Nature of Price : Variable  
 Base Date : 01.01.2015

1.	Name of the Item (giving size)	
2.	Quantity Offered (Nos.)	
3.	Quoted variable price (EX-Works) inclusive of packing & forwarding forming part of production cost per unit	
4.	Discount if any	
5.	Rate of ED, if applicable @	
6.	Rate of CST, if applicable @	
7.	Rate of VAT, if applicable @	
8.	Handling & Cartage charges etc./unit	
9.	Freight charges	
10.	Transit Insurance charges	
11.	F.O.R. Destination price/ unit (3+4+5+6+7+8+9+10)	

Signature\_\_\_\_\_

**IMPORTANT NOTES:**

- Rate of ED & CST & VAT applicable must be mentioned clearly otherwise maximum rate of ED & CST & VAT shall be taken into account for evaluation purposes.
- Only variable rates may be quoted, otherwise bid shall be rejected.
- In case quoted prices given in this Annexure do not tally with the ones given in the main tender, the one given here shall be considered as the quoted price. Any arithmetical error shall be considered to the advantage of the purchaser.
- The firms indicating 'Nil' or concessional rate of ED/CST/VAT will have to absorb the ED/CST/VAT up to full rate applicable at the time of tendering. The firm who do not agree to this stipulation or indicate ED/CST/VAT as extra without indicating the applicable rates shall be loaded with maximum rate of ED/CST/VAT.
- Separate sheet for each type/size of the items quoted
- Scanned copy of relevant IEEMA circulars may be provided with the bid and base date along with base rates of relevant items such as E.C. Grade Aluminium Ingots, Electrolytic high grade zinc, Steel Billets and all India average consumer price index number for Industrial Workers may be mentioned, where required.

**ANNEXURE - B****SCHEDULE OF REQUIREMENTS AND DELIVERY**

<b>Sr. No</b>	<b>Item</b>	<b>Quantity</b>
1.	Hardware Fittings For Earth wire of Size 7/3.15mm	
i.	Suspension Clamp	800 Nos.
ii.	4 R Stock Bridge Dampers	1100 Nos.

**IMPORTANT NOTES:**

- In case the tender is silent about any clause part A & B of the specification, it shall be assumed acceptable to him.
- Type test certificates complete in all respect from Govt. approved test house in respect of each item should be sent along with the offer.
- The Bidders should invariably supply information on all Annexures attached.

**DELIVERY:**

Commencement: Half of material within one and half month from the date of receipt of P.O.

Completion: Rest within one and half month thereafter.

Note : i) Early supply may be taken keeping in view the requirement of works.

ii) Delivery may be taken as per requirement of works

However, the purchaser reserves the right to divide the tendered quantity of the material as per requirement. In case the order is placed on more than one firm, the delivery period shall be changed on pro-rata basis.



**ANNEXURE -C****PERFORMA FOR BANK GUARANTEE**

(TO BE EXECUTED ON NON-JUDICIAL STAMP PAPER OF THE APPROPRIATE VALUE

\_\_\_\_\_ BANK GUARANTEE NO. \_\_\_\_\_

\_\_\_\_\_ DATED \_\_\_\_\_.

1. The bank of \_\_\_\_\_ hereby agrees un-equivocally and unconditionally to pay, within 48 hours, on demand in writing from the Chief Engineer, Punjab State Transmission Corporation Ltd., or any officer authorized by him in this behalf, of any amount up to and not exceeding Rs. \_\_\_\_\_ (in words Rupees \_\_\_\_\_) to the Punjab State Transmission Corporation Ltd., on behalf of M/s. \_\_\_\_\_ who have entered into a contract or have unconditionally accepted for the Purchase Order No. \_\_\_\_\_ dated \_\_\_\_\_ for the supply of material \_\_\_\_\_ for order value of Rs. \_\_\_\_\_.
2. This guarantee shall be and binding on this bank up to and including \_\_\_\_\_ and shall not be terminable by notice or on account of any change in the constitution of the Bank or the firm of contractor/suppliers or by any other reasons what-so-ever and our liability hereunder shall not be impaired or discharged by any extension of time or variation of alternation made, given, conceded or agreed with or without our knowledge or consent by or between the parties to the said contract/purchase order.
  1. Our liability under this Guarantee is restricted to Rs. \_\_\_\_\_ (in word Rs. \_\_\_\_\_). Our guarantee shall remain in until \_\_\_\_\_.
  2. We hereby agree that any claim or dispute arising under this deed shall fall with the jurisdiction of competent courts at Patiala only.  
We hereby further declared that this Deed has been executed by our lawfully constituted attorney legally competent to sign and execute such deeds.

Signature \_\_\_\_\_

For Pro

Bank \_\_\_\_\_

**ANNEXURE-D****UNDERTAKING FORM FOR ORDER PREFERENCE**

(TO BE ENTERED ON A NON-JUDICIAL STAMPED PAPER OF Rs. 15/- ONLY)

We \_\_\_\_\_ state that our works are situated in the state of Punjab and we claim "Order Preference" as stipulated in the PSTCL tender specification No. \_\_\_\_\_ due on \_\_\_\_\_ against which we have submitted our tender No. \_\_\_\_\_ dated \_\_\_\_\_. We undertake to execute the order/contract if placed/awarded on to us even by counter offer at the rates worked out by Punjab State Transmission Corporation Ltd., in accordance with its Purchase Regulations. It is further understood that in the event of refusal by us or failure on our part to execute the order/contract (full or part) placed/awarded on to us under "Order Preference" on any account what-so-ever, the Punjab State Transmission Corporation Ltd., shall have the right to forfeit the earnest money deposited by us and we shall have no claim for the refund thereof. The Punjab State Transmission Corporation Ltd., shall also have the right to suspend business dealing with us and to black-list out firm, without prejudice to other rights accruing to the Punjab State Transmission Corporation Ltd., under the purchase Order/Contract, if placed/awarded on to us.

Signature of Constituted attorney

**ANNEXURE-E****CONTRACT AGREEMENT FORM**

(TO BE ENTERED ON NON-JUDICIAL STAMP PAPER WORTH Rs. 15 ONLY)

This contract agreement made this \_\_\_\_\_ day of \_\_\_\_\_ in the year \_\_\_\_\_ between the Punjab State Transmission Corporation Ltd., herein after called 'Purchaser' and M/s. \_\_\_\_\_ having their Regd. office at \_\_\_\_\_ herein after called Contractor, for the supply and delivery/construction of in accordance with Purchaser's Enquiry No. \_\_\_\_\_ dated. \_\_\_\_\_ and Contractor's Proposal No. \_\_\_\_\_ dated. \_\_\_\_\_.

This is in confirmation of the advance acceptance notified in the Purchaser's letter No. \_\_\_\_\_ Wherein, the Purchaser has accepted the proposal of the contractor for supply and delivery/construction of \_\_\_\_\_ as per purchase/work order No. \_\_\_\_\_ dated. \_\_\_\_\_.

In view of the foregoing, the Purchaser and the Contractor have agreed to the scope of work and the terms and conditions of the order settled between them.

The NIT / tender specification, the Contractor's proposal and related correspondence and the P.O. acknowledge/accepted by the Contractor form part of this agreement.

This agreement contains \_\_\_\_\_ pages. In witness where of the parties here to have affixed their signatures on the day, month and the year written as above.

CONTRACTOR

PURCHASER

**ANNEXURE – F****PERFORMA FOR ELICITING INFORMATION FOR APPRAISAL OF FIRM'S CAPABILITY AND CAPACITY TO MANUFACTURE ITEM (S) EQUIPMENT AS PER REQUIREMENTS OF PSTCL TENDER ENQUIRY No. STQ- 4005**1. (A) Name of the Tendering Firm:

- Complete Address of the office:
- Telegraphic Address
- Telephone Number
- E-mail
- FAX Number

(B) Name of the two Responsible Persons:

- Officer with Designation  
(Managing Director/Partner/  
Chief Engineer/Works Engineer etc.) along with their address, Income Tax  
Permanent Account No.
- Day on which weekly holiday is  
Observed in the office

(C) Complete Address of the Works:

- Telegraphic Address
- Telephone Number
- E-mail & FAX No.
- Name of the two Responsible Persons  
With Designation (Managing Director/  
Partner/Chief Engineer/Works Engineer etc.)
- Day on which weekly holiday is observed

2. NAME, ADDRESS & TELEPHONE NO. OF TWO REFERENCE HAVING FACILITIES OF P&T TELEPHONE

- |                 |                    |
|-----------------|--------------------|
| • Name          | i) Name            |
| • Address       | ii) Address        |
| • Telephone No. | iii) Telephone No. |

3. CONSTITUTION OF THE FIRM

- Private or Public Ltd.
- Registered under the Companies Act  
Or any other act, giving registration  
No. & date
- iii) Year of establishment

4. FINANCIAL POSITION

- Land (Area & Value)
- Building (Cover & Value)
- Plant & Machinery
- Total Drawing Limit from Bank
- Annual Financial Turn Over (duly  
Audited for the last three years)
- Latest Income Tax Clearance Certificates

5. MAN POWER

- Graduate Engineer(s)
- Diploma Holders
- Skilled Workers
- Unskilled Workers

6. PRODUCTION CAPACITY PER MONTH OF THE ITEM COVERED IN YOUR QUOTATION AND JUSTIFICATION FOR ASSESSMENT:
- Detail of Plant & machinery installed  
(Please attach separate sheet, if necessary)
  - Detail of Raw Material
  - Stock in Hand
  - Source of Raw Material
  - In case, any Raw Material are required to Be imported, indicate arrangement for procurement
  - Quality Control exercise in procurement of its material
7. a) Detail of manufacturing process  
b) Scheme of quality control
- During manufacturing
  - At the finish stage
  - Whether any record is being maintained in respect of quality Control exercised.
8. DETAILS OF TESTING FACILITIES AVAILABLE WITH THE FIRM. (INFORMATION MAY BE SUPPLIED IN THE ENCLOSED PERFORMA)
9. DETAIL OF ORDER EXECUTED/ UNDER EXECUTION DURING THE LAST THREE YEARS
- with PSTCL
  - Other State Electricity Boards/State Govt./ Govt. of India and their institutions/undertakings
  - Other important customers.
10. a) Whether the items are on Punjab Govt. DGS & D/Central Govt. approved rate contracts (attach copies of rate contract)  
b) Whether the firm is licensed to use ISI mark or any other Govt. quality mark (copies of latest test certificates issued by Govt. laboratories and recognized test houses)  
c) Whether items offered conforms to ISS or any other internationally recognized standards, if so give reference.
11. a) Manufacturing capacity of the firm per month  
b) Current commitments / order booking of the firm with other SEBs/ State utilities / Pvt. Concerns  
c) Spare monthly capacity available for the instant Tender Enquiry of PSTCL

Signature of authorized  
Signatory of the firm with stamp

- Note: 1. Please attach additional sheets with stamps where required.  
2. Copies of documents attached with the Performa should be attested by firms authorized person with stamp mark of the firm.  
3. Detail of documents submitted shall be marked with page no. and index may be submitted accordingly.

**ANNEXURE-G****SCHEDULE OF GENERAL INFORMATION**  
(TO BE FILLED BY THE TENDERER)

1.	Name, address & telephone Nos. of manufacture/ Principals.	_____
2.	PAN No.& proof of filling Income Tax return for last 3 years of manufacturer/principals.	_____
3.	Name & address of supplier/firm/company.	_____
4.	PAN No.& Income Tax return for last 3 years of supplier/firm/company.	_____
5.	Name address & telephone no. of Director /Partners/proprietors.	_____
6.	PAN No.& proof of filling income tax return for last 3 years of Director/Partner/Prop.	_____
7.	Telegraphic address.	_____
8.	Turnover of the firm for the last 3 years.	_____
9.	Bank references.	_____
10.	Testing facilities available at works for routine and acceptance tests (furnished details of testing equipment).	_____
11.	Name of works Manager/Managing Director.	_____
12.	Telephone No. of the office at manufacture works/supplier to whom reference should be made for expeditious technical co-ordination.	_____
13.	Whether holding ISI license, if yes, enclosed Photostat copy.	_____
14.	Whether the material carries State Quality Mark, if yes, enclose Photostat copy.	_____
15.	Memorandum and Article of Association of private Ltd., or Public Ltd., company /partnership deed in case of partnership firm (To be attached).	_____

Dated:

SIGNATURE OF TENDERER  
NAME DESIGNATION  
SEAL OF FIRM/COMPANY.

**ANNEXURE - H****SCHEDULE OF DEVIATIONS**

Bidders shall carefully state below any and all points in this proposal, which are not in accordance with Technical Specification and the general instructions: -

Sr. No.	Page No.	Deviation if any
<b><u>A. TECHNICAL</u></b>		
1.		
2.		
3.		
4.		
5.		

**B. COMMERCIAL**

- 1.
- 2.
- 3.
- 4.
- 5.

Bidders hereby certify that the above mentioned are the only deviations from Purchasers aforesaid specification and General conditions.

Signature\_\_\_\_\_

Name \_\_\_\_\_

Designation\_\_\_\_\_

Seal of the firm \_\_\_\_\_

Dated: \_\_\_\_\_

## ANNEXURE-I

## TESTING FACILITIES

Name of test	Detail of Test facilities available	Remarks
<b>1. Tests on Raw Material</b>		
i)		
ii)		
iii)		
iv)		
_____		
_____		
<b>2. Routine Tests</b>		
i)		
ii)		
iii)		
iv)		
_____		
_____		
<b>3. Type Tests</b>		
i)		
ii)		
iii)		
iv)		
_____		
_____		
<b>4. Acceptance Tests</b>		
i)		
ii)		
iii)		
iv)		
_____		
_____		

Note: In case testing facilities are not available for tests, indicate in the remarks column from which testing house(s)/Institution these tests will be carried out.



**ANNEXURE-J****TECHNICAL INFORMATION TO BE FURNISHED BY TENDERERS.****IMPORTANT NOTE:**

The technical data as asked for here under must be complete in every respect along with necessary type test reports without which the offer shall be liable for rejection without any further reference on the issue.

Please write N.A. against item, which are not applicable.

<b>Sr. No.</b>		<b>DESCRIPTION</b>	
1.		Name of Firm	
2.	a)	Whether Govt. concern, Pvt Ltd., Co., PSU or SSI Unit	
	b)	Whether documents in support of above like photo copy of Regd. with Deptt. of industries in case of SSI unit, attached?	
3.	a)	Whether the Firm holds ISI certification, PQM, ISO 9000 series certification.	
	b)	If so, whether documents in support of above attached?	
	c)	Whether the fittings offered carry ISI/ISO mark	
4.		Type & size of melting furnace for moulding/ casting.	
5.		Whether material is heat treated or non-heat treated	
6.		Particulars regarding Mechanical strength of Malleable Casting;	
	i)	Min. Tensile Strength (KG/mm <sup>2</sup> )	
	ii)	Min. Elongation (%)	
	iii)	Max. Brinell Hardness (BHN)	
7.		Whether firms detailed dimensioned Drg. in respect of each item attached?.	
8.		Whether type test certificates as per items offered attached?	
9.		Whether all acceptance tests can be carried out at firm's premises?	
10.		Whether list/details of Testing Equipment & Facilities available with the firm attached?	

## Annexure-K-1

**GURANTEED TECHNICAL PARTICULARS OF SUSPENSION FITTINGS FOR EARTHWIRE OF SIZE 7/3.15 MM**

1. Applicable Standards
2. Maker's Name and Address
3. Drg.No.(s).
4. Requirements

<b><u>S.No.</u></b>	<b><u>Description</u></b>	<b><u>Qty</u></b>	<b><u>Material</u></b>
i)	Eye Hook		
ii)	Suspension clamp keeper		
iii)	U-Bolt (12mm size)		
iv)	Split pin		
v)	Spring washers (12mm size)		
vi)	Plain washers (12mm size)		
vii)	Nuts (12mm size)		
viii)	Dimensions		
ix)	Tolerance		
x)	Slip strength		
xi)	UTS		

## ANNEXURE-K-2

**GURANTEED TECHNICAL PARTICULARS OF 4R-S.B. DAMPERS FOR EARTH WIRE OF SIZE 7/3.15 MM**

Drawing No. \_\_\_\_\_ :

2. SIZE QUANTITY & MATERIAL FOR ONE FITTING:

<u>S.No.</u>	<u>Description</u>	<u>Qty.</u>	<u>Material</u>
1	Material of Damper Mass	_____	_____
2	Messenger Cable (No. of strands/dia of each strand)	_____	_____
3.	Clamp Body	_____	_____
4.	Bolt Size	_____	_____
5.	Flat Washers	_____	_____
6.	Spring Washer	_____	_____
7.	Mass Pull off weight	_____	_____
8.	Clamp Bolt Tightening Torque	_____	_____
9.	Slip Strength of Clamp on Conductor	_____	_____
	a) Before Fatigue Test	_____	_____
	b) After Fatigue Test	_____	_____
10.	Applicable Standard for Damper	_____	_____
11.	Standard for Galvanizing	_____	_____
12.	Micro Strain Limit	_____	_____
13.	Approx. Wt. Of Damper Assy.	_____	_____
14.	Resonance Frequencies	_____	_____
	Tolerance for Lower than 15 Hz	_____	_____
	Tolerance for Higher than 15 Hz	_____	_____
15.	Min. UTS of stranded messenger Cable	_____	_____
16.	Gen. Tolerance	_____	_____

NOTE: All the ferrous parts to be Hot Dip Galvanized except S.S. Parts and Spring Washers, the Later being Electro- Galvanized as per IS: 1573

## ANNEXURE-L

**GENERAL COMMERCIAL PARTICULARS****(Following information must be uploaded by the bidders)**

Excise Duty	
• Rate considered in quoted prices	@
• MODVAT benefit considered or not	
• In case Nil / Concessional rate of ED is applicable then maximum rate of ED applicable at the time of tendering will be absorbed by the bidder (Yes/No)	
CST / VAT	
• Rate considered in quoted prices	@
• In case Nil / Concessional rate of CST/ VAT is applicable then maximum rate of CST/ VAT applicable at the time of tendering will be absorbed by the bidder (Yes/No)	
Validity of offer (min. 120 days)	
Whether Schedule of delivery as per specification (Yes/No)	
Whether Terms of Payment as per specification (Yes/No)	
Nature of Price	Variable
Base date of quoted prices w.r.t relevant IEEMA circular for Price of Electrolytic high grade zinc, Price of Steel Billets (scanned copy to be attached)	01.01.2015
Price /MT of Electrolytic high grade zinc Rs/MT) as per IEEMA circular.	
Average price of steel billet of size 100mm (Rs/MT) as per IEEMA circular.	
Any other information to be mentioned by the bidders	

**ANNEXURE-M****UNDERTAKING FOR NON PAYMENT OF COMMISSION ETC.**

We will not pay commission etc. or engage any commission agent or liaison agent for dealing with the PSTCL in any matter including purchase of specification etc.

Signature of Bidder

Name

Designation

Dated:

Seal of Firm/Company

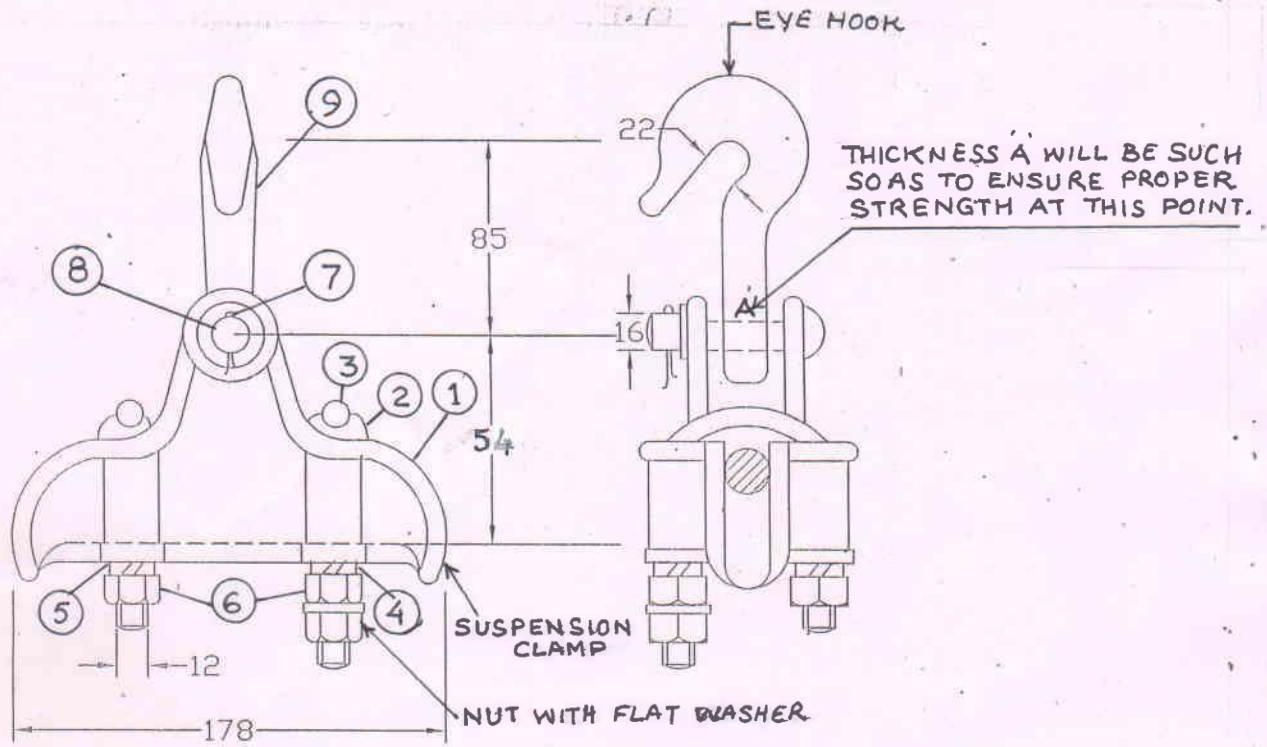

Sr. no.	Description	Quantity	Material
1.	Clamp body	1	Malleable Iron
2.	Keeper piece	1	-do-
3.	U-bolts	2	M.S
4.	Spring washer	4	steel
5.	washers	4	M.S
6.	Nuts	5	-do-
7.	cotter pin	1	Brass
8.	Rivet	1	M S
9.	Hook Eye	1	Forged steel

**Notes:-**

- |    |  |
|----|--|
| 1. | All dimensions are in mm.                                  |
| 2. | All ferrous parts to be hot dip galvanized as per IS-2633. |
| 3. | Breaking strength 7000Kg.                                  |
| 4. | Gen Tolerance + 2%.  |
| 5. | Weight to be indicated.                                    |

PUNJAB STATE TRANSMISSION CORPORATION  
LIMITED

Suspension clamp Hardware Fitting Suitable for Earth  
wire of size 7/3.15 MM

DRG. NO. HW/TF-7305/R1

SCALE-N.T.S

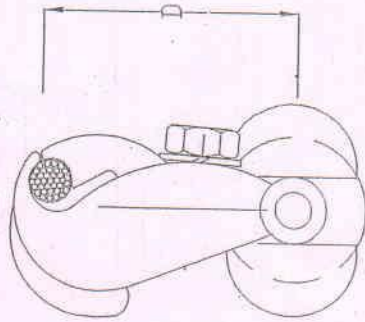
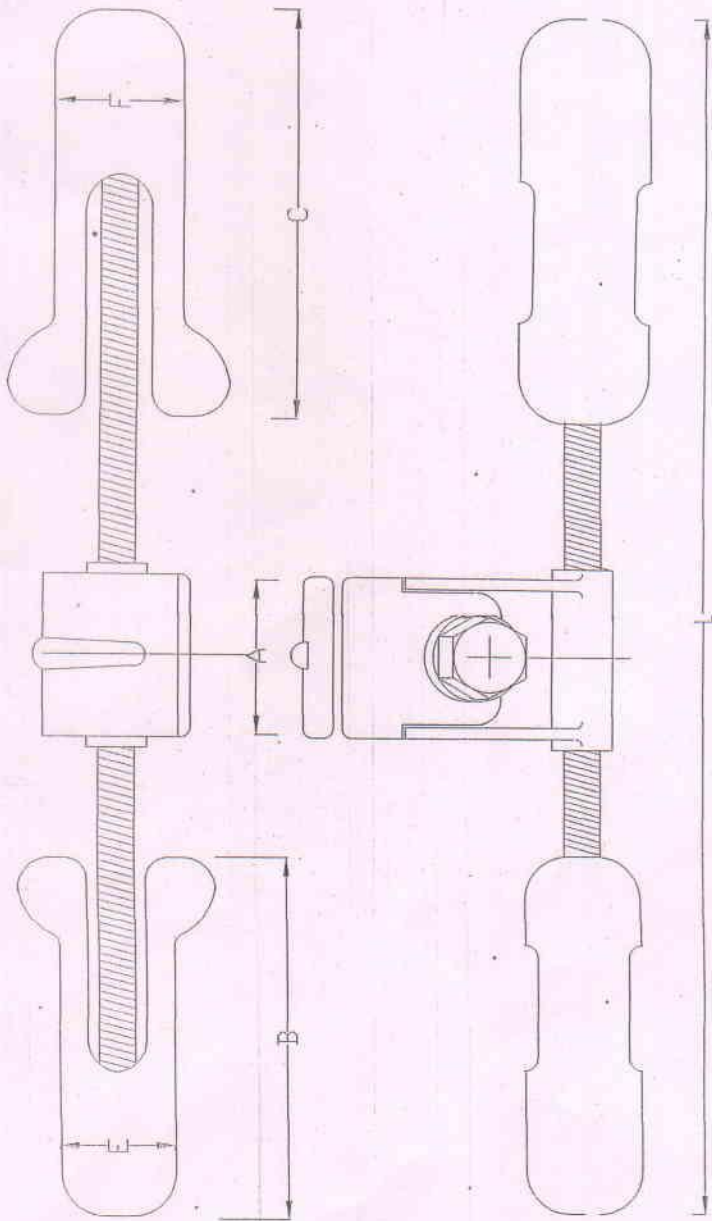

**Notes:-**

- All Dimensions shall be given in mm.
- Fatigue limit resonant frequencies 10 million cycles (+ 1mm amplitude).
- S.B Dampers conforming to IS-9708/1993 with amendments.
- Tensile strength of Messenger cable-135 Kg/Sq. mm.
- All Ferrous parts to be hot dip galvanized as per IS-2633.
- No. of dampers required for different spans may be indicated. Fixing details of dampers to be given.
- Micro strain limit below 150 micro strains at selected wind velocities.
- Information for Messenger cable like bolt size, torque on bolt, slip strength, mass pull off, assembly weight, and all dimensions of dampers be provided.
- Placement chart for various span lengths from 250 mt to 500 mt must be supplied with the tender, specifically mentioning the position of bigger/smaller dampers masses with respect to the tower.

Span (in mtr.)	Spacing in suspension for single Damper	Spacing in tension for single Damper	Spacing in suspension for Double Damper	Spacing in Tension for Double Damper
250				
300				
350				
400				
450				
500				

Sr. no.	Description	Material Details
1.	Damper mass, big and small	Galvanized cast iron
2.	Messenger Cable	High tension Stranded steel wire
3.	Hook and cover half clamp	Aluminum alloy die cast
4.	Flat washer	Hot dip galvanized fabricated steel
5.	Bolt	Hot dip galvanized steel
6.	Spring washer	Special steel, electro-galvanized

**PUNJAB STATE TRANSMISSION CORPORATION  
LIMITED**

**4R "Type" Stock Bridge Vibration Dampers Suitable  
for Earth wire of size 7/3.15MM**

<b>DRG. NO. HW/TF-7341</b>	<b>SCALE-N.T.S</b>
----------------------------	--------------------